

风机参数		
名称	数据	单位
额定电压	220	V AC
额定电流	0.22	A
电容	2	uF
额定转速	2600	RPM

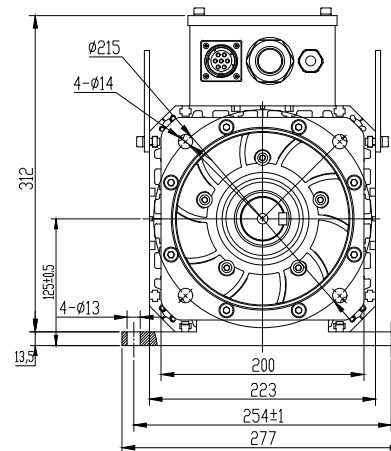
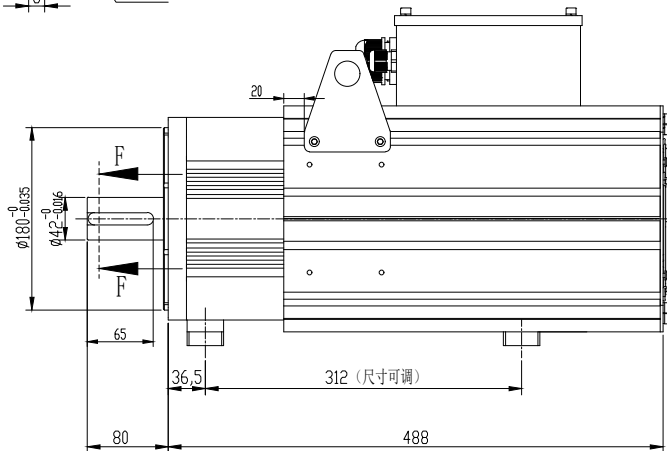
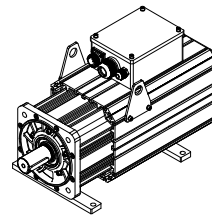
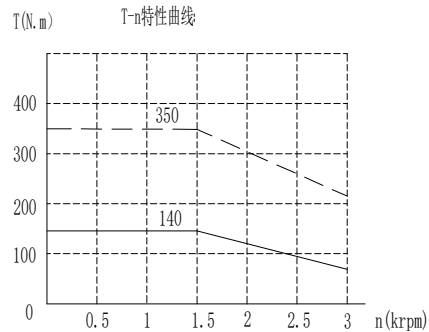
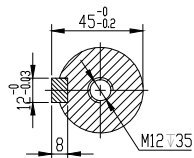

### 电机参数 Motor parameter

名称	单位	数据
额定功率 Rated power	kW	22
额定电压 Rated voltage	V	380
额定转速 Rated speed	rpm	1500
最高转速 Maximum speed	rpm	3000
额定频率 Rated frequency	Hz	100
最高频率 Maximum frequency	Hz	200
额定电流 Rated current	A	52
峰值电流 Peak current	A	130
额定转矩 Rated torque	N.m	140
峰值转矩 Peak torque	N.m	350
线电阻 Line resistance	Ω	0.25
线电感 Line inductance	mH	6.9
D轴电感 D-axis inductance	mH	2.2
Q轴电感 Q-axis inductance	mH	4.6
电气时间常数 electrical time constant	ms	27.6
线反电势 Back electromotive force	V/Krpm	169
转矩系数 Torque coefficient	N.m/Arms	2.69
转子惯量 Rotor inertia	kg.m <sup>2</sup> ×10 <sup>-4</sup>	131
反馈元件 Feedback element		23bit
冷却方式 Cooling method		Forced air cooling
绝缘等级 Insulation class		H
防护等级 Protection class		IP54

### 抱闸参数 Holding brake parameter

抱闸电压 Holding brake voltage	V	/
抱闸电流 Holding brake current	A	/
抱闸转矩 Holding brake torque	N.m	/
抱闸功率 Holding brake power	W	/
抱闸电阻 Holding brake resistance	Ω	/
绝缘等级 Insulation level		F
绝缘电阻 Insulation resistance	MΩ	/
绝缘耐压 Dielectric strength		1200V/5mA/1S
使用温度 Operating temperature	℃	/
释放电压 Release voltage	V	/
吸引电压 Attraction voltage	V	/
最大转速 Maximum speed	r/min	/
运转噪音 Running noise	dB	/

电机动力引出线				电机编码器引出线								电机端子排引出线						
位号	1	2	3	4	1	2	3	4	5	6	7	8---15	PTC+	PTC-	KTY84+	KTY84-	220	0
颜色	红	黄	蓝	黄绿	屏蔽	白	棕	黄	黑	蓝	红	/	蓝	蓝	棕	白	蓝	黑
定义	U	V	W	PE	PE	E-	E+	SD-	0V	SD+	+5V	/	PTC130+	PTC130-	KTY84+	KTY84-	风扇电源+	风扇电源-
视图																		
	防水接头: PG29				航插YD28K15芯								防水接头W20*1.5					

**KCFA** 浙江禾川科技股份有限公司

视图

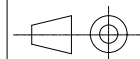

物料名称:	伺服电机	设计:
物料编码:	见表格	日期:
物料规格:	SV-X7E MM20-22D15CH-DNOF-0BH	版本: