

电机性能规格
MOTOR PERFORMANCE SPECIFICATION

法兰 FLANGE	80
额定功率(W) RATED POWER	750
额定电压(V) RATED VOLTAGE	DC48
每相感应电压常数(mV/(r/min)) INDUCED VOLTAGE CONSTANT PER PHASE	*A
额定电流(A) RATED CURRENT	21
瞬时最大电流(A) INSTANTANEOUS MAXIMUM CURRENT	-
额定转矩(N.m) RATED TORQUE	2.39
瞬时最大转矩(N.m) INSTANTANEOUS MAXIMUM TORQUE	7.32
线圈电阻(Ω) COIL RESISTANCE	*A
线圈电感(mH) COIL INDUCTANCE	*A
额定转速(rpm) RATED ROTATION SPEED	3000
最高转速(rpm) MAXIMUM ROTATION SPEED	4000
转子转动惯量无刹车(10 ⁻⁴ kg.m ²) ROTOR MOMENT OF INERTIA WITHOUT BRAKE	0.988
转子转动惯量带刹车(10 ⁻⁴ kg.m ²) ROTOR MOMENT OF INERTIA WITH BRAKE	1.2
转子极对数P NUMBER OF ROTOR POLES P	4
定子槽数S NUMBER OF STATOR SLOTS S	12
编码器类型 ENCODER RESOLUTION	17bit
电机绝缘等级 MOTOR INSULATION LEVEL	F
电机防护等级 MOTOR PROTECTION LEVEL	IP65

信号线连接
Encoder connector

端子号码 TERMINAL NUMBER	信号名 SIGNAL NAME	颜色 COLOR
1	BATT	赤(黑色标记) RED(BLACK MARKER)
2	+DO	白(赤色标记) WHITE(RED MARKER)
3	-DO	白 WHITE
4	VCC	橙 ORANGE
5	GND	青 BLUE
6	SHIELD	绿 GREEN

轴端面局部:
Shaft-end dimension:

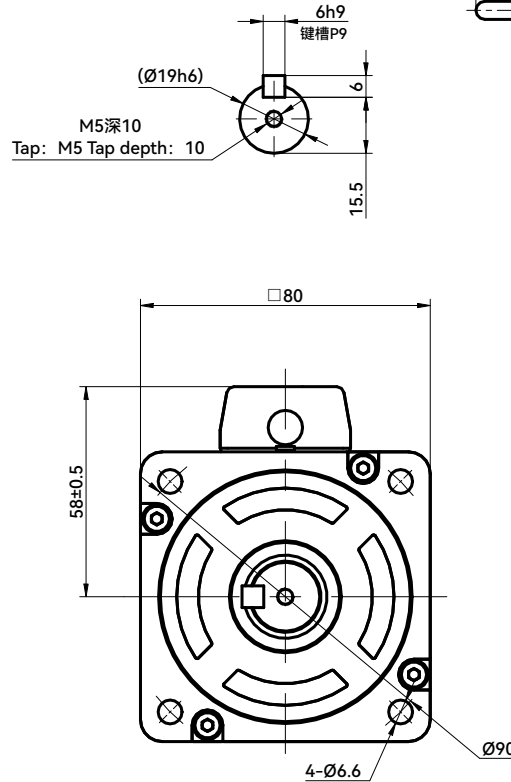

平键长度:
Flat key length:

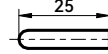

信号线连接器:
Encoder connector:

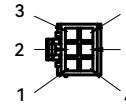

制动器连接器:
Brake connector:



动力线连接器:
Power connector:

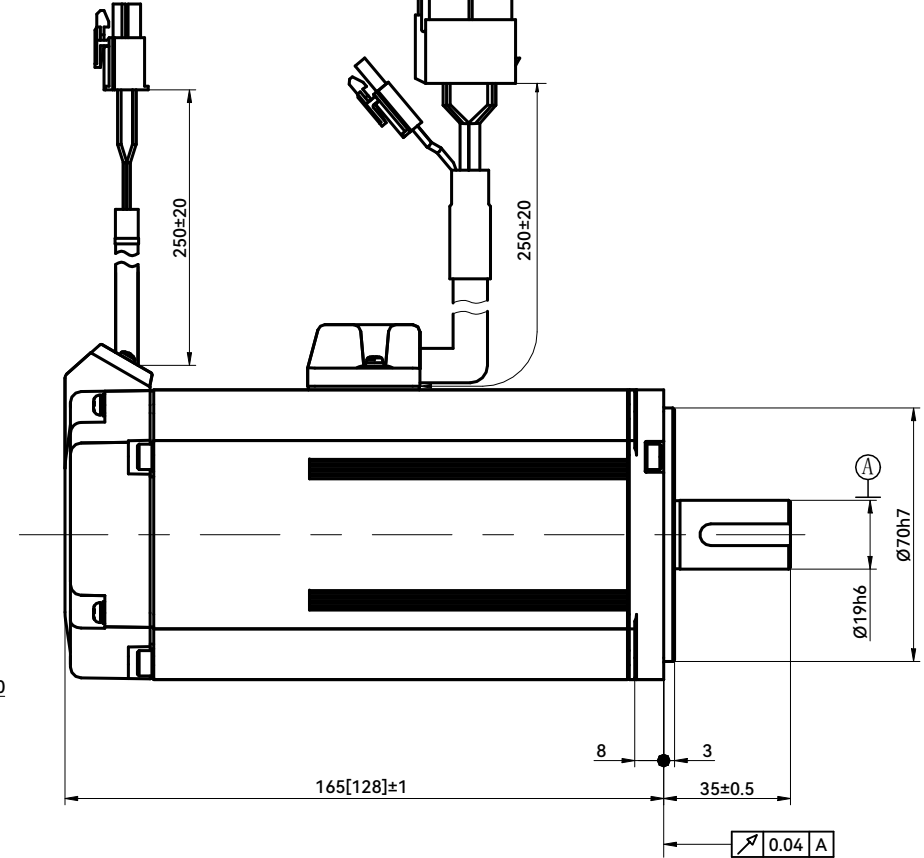
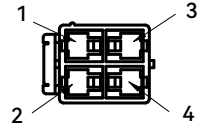

动力线连接
Power connector

端子号码 TERMINAL NUMBER	信号名 SIGNAL NAME	颜色 COLOR
1	U	赤 RED
2	V	白 WHITE
3	W	黑 BLACK
4	FG	绿 GREEN

制动器连接
Brake connector

端子号码 TERMINAL NUMBER	信号名 SIGNAL NAME	颜色 COLOR
1	BRK1	橙 ORANGE
2	BRK2	棕 BROWN

注: 1. 方形括号内尺寸为不带刹车机种长度;
2. *A处详细参数请咨询我司技术人员。

Note: 1. Dimensions in brackets are for non-brake type length;
2. Please consult our technical personnel for detailed parameters at location *A.

客户回签
Customer signature

						HCFA 浙江禾川科技股份有限公司 Zhejiang Hechuan Technology Co.,Ltd		
						48V-750W伺服电机 48V-750W Servo motor		
						X2MA075A-N(B)6LA		
标记 MARK	处数 NUMBER OF REVISED	分区 SECTION	更改文件号 REVISED DOCUMENT NUMBER	签名 SIGNATURE	年月日 DATE	阶段标记 STAGE MARKER	重量 WEIGHT	比例 SCALE
设计 DESIGN	何昊楠		2023.8.1	标准化 STANDARDIZATION				
审核 VERIFY	徐安宇		2023.8.1					
工艺 CRAFT				批准 APPROVE	2023.8.1	共 页 第 页 PAGE ,ALTOGETHER PAGE		