

### 电机规格 Motor Specifications

电机型号 Motor Model	X6MM750H-N4LD
适配驱动器电压 V (rms) Typical Drive Voltages	380
直流母线电压 V (dc) Basic DC Bus Voltage	540
额定功率 kW Rated Output Power	7.5
额定转速 rpm Rated Speed	1500
最高转速 rpm Max. Speed	3000
额定转矩 Nm Rated Torque	47.8
堵转转矩 Nm Continuous Stall Torque	47.8
瞬时峰值扭矩 Nm Peak Torque	119.4
额定电流 A (rms) Rated Current	25.3
堵转电流 A (rms) Continuous Stall Current	25.3
瞬时峰值电流 A (rms) Peak Current	65.8
线反电势常数V (rms) / K rpm Voltage Constant	128.7
转矩常数Nm / A (rms) Torque Constant	2.1
线电阻 $\Omega$ @20° C Winding Resistance (Line-Line)	0.19
线电感mH (typ.) Winding Inductance (Line-Line)	5.1
转子惯量kg m <sup>2</sup> Inertia	136.4X10 <sup>-4</sup>
电气时间常数ms Electrical Time Constant	26.8
极对数 Rotor Poles	5
编码器 Encoder	23位绝对值
轴向载荷 N Shaft Load - Axial	980
径向载荷 N Shaft Load - Radial (End of Shaft)	2058
防护等级 Protection Class	IP65
绝缘等级 Insulation Class	F
重量 kg Weight	28.2

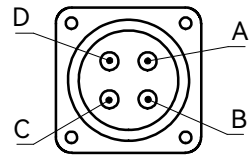
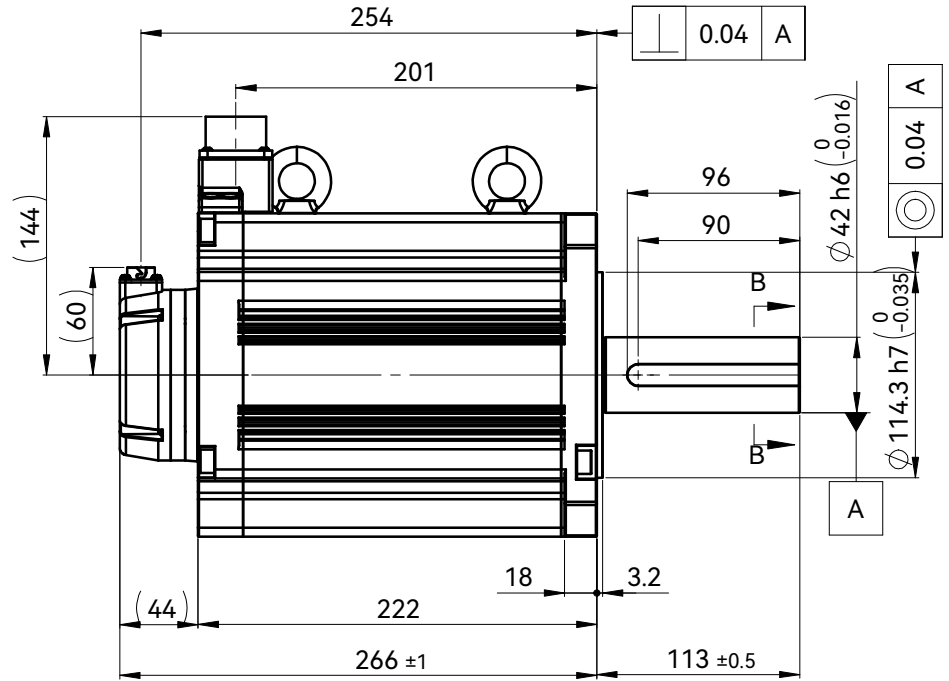
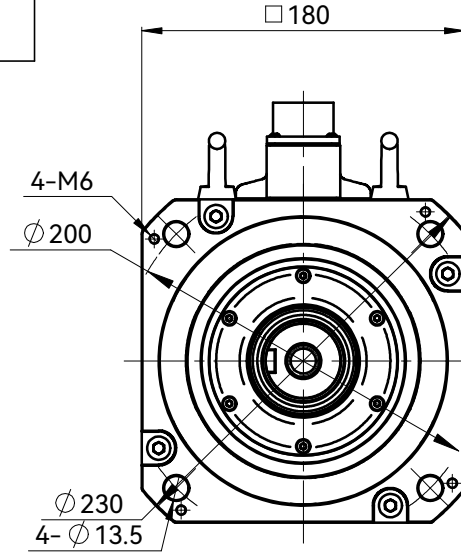

电机动力端 Motor Power Connection

针位 PIN No.	功能定义 Function
A	U
B	V
C	W
D	C.G

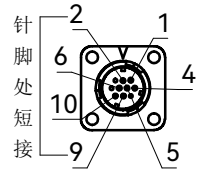

编码器端 Encoder Connection

针位 PIN No.	功能定义 Function
1	VCC
2	GND
3	-
4	BAT
5	+D0
6	-D0
7	-
8	-
9	-
10	SHIELD

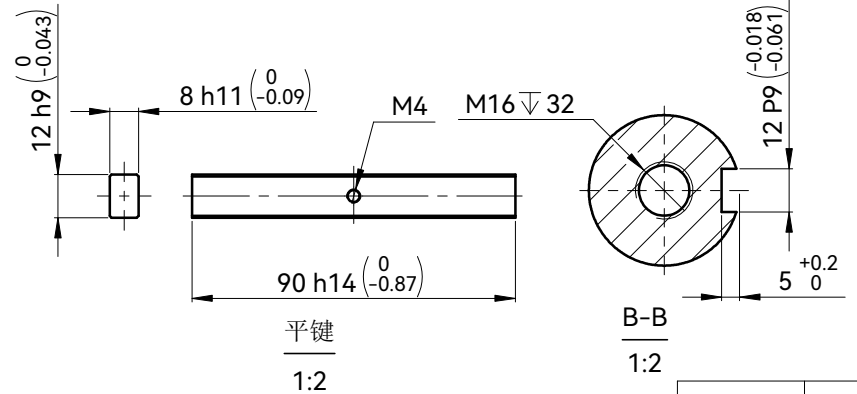

备注:  
notes

- GB/T 1096 键 B12x8x90 随电机一起包装, 但未安装。  
GB/T 1096 Key B12x8x90 is shipped with motor, but not installed.
- 防护等级IP65(除了轴上没装油封和非密封连接器情况)。  
IP65 (except Shaft without seal and non-sealed connectors)

						客户回签		
						HCFA 浙江禾川科技股份有限公司		
						伺服电机(7.5kW)		
标记	处数	分区	更改文件号	签名	年月日			
设计	ZML	070721	标准化			阶段标记	重量	比例
审核						1:4		
工艺			批准			共张	第张	X6MM750H-N4LD