

电机规格 Motor Specifications

电机型号 Motor Model	X6MM500A-N4LD
适配驱动器电压 V (rms) Typical Drive Voltages	380
直流母线电压 V (dc) Basic DC Bus Voltage	540
额定功率 kW Rated Output Power	5
额定转速 rpm Rated Speed	2000
最高转速 rpm Max. Speed	3000
额定转矩 Nm Rated Torque	23.9
堵转转矩 Nm Continuous Stall Torque	23.9
瞬时峰值扭矩 Nm Peak Torque	71.6
额定电流 A (rms) Rated Current	13.5
堵转电流 A (rms) Continuous Stall Current	13.5
瞬时峰值电流 A (rms) Peak Current	45
线反电势常数 V (rms) / K rpm Voltage Constant	123.5
转矩常数 Nm / A (rms) Torque Constant	2.04
线电阻 Ω @20° C Winding Resistance (Line-Line)	0.41
线电感 mH (typ.) Winding Inductance (Line-Line)	8.9 \triangle
转子惯量 kg m ² Inertia	66.7X10 ⁻⁴
电气时间常数 ms Electrical Time Constant	21.7 \triangle
极对数 Rotor Poles	5
编码器 Encoder	23位绝对值
轴向载荷 N Shaft Load - Axial	343
径向载荷 N Shaft Load - Radial (End of Shaft)	784
防护等级 Protection Class	IP65
绝缘等级 Insulation Class	F
重量 kg Weight	19.4

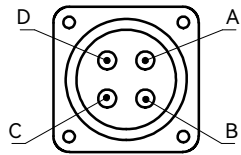
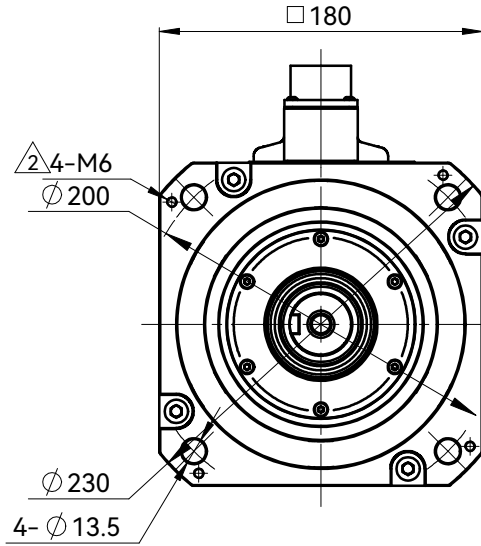

电机动力端 Motor Power Connection

针位 PIN No.	功能定义 Function
A	U
B	V
C	W
D	C.G

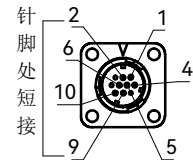

编码器端 Encoder Connection

针位 PIN No.	功能定义 Function
1	VCC
2	GND
3	-
4	BAT
5	+D0
6	-D0
7	-
8	-
9	-
10	SHIELD

备注:
notes

- GB/T 1096 键 B10x8x50 随电机一起包装, 但未安装。
GB/T 1096 Key B10x8x50 is shipped with motor, but not installed.
- 防护等级IP65(除了轴上没装油封和非密封连接器情况)。
IP65 (except Shaft without seal and non-sealed connectors)

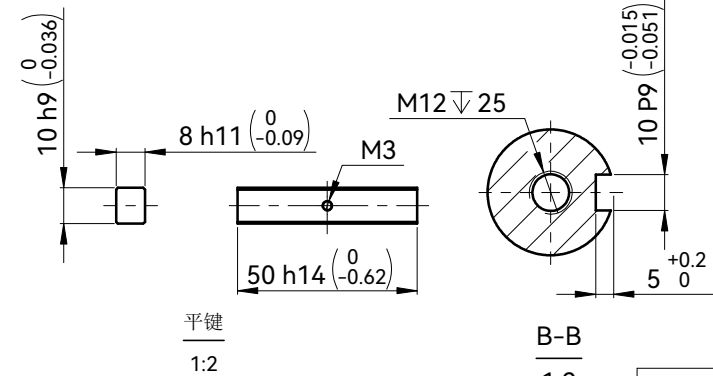
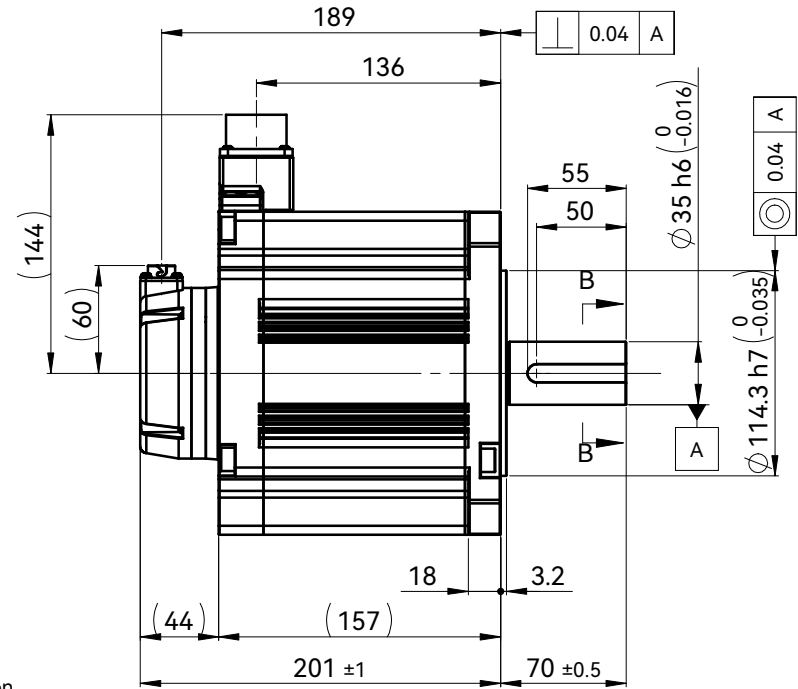

客户回签	
HCFA 浙江禾川科技股份有限公司	
伺服电机(5kW)	
X6MM500A-N4LD	

标记	3	EC001966	ZML	063021	阶段标记	重量	比例
设计	ZML	041020	标准化				1:4
审核					共张	第张	
工艺			批准				