

电机规格 Motor Specifications

电机型号 Motor Model	X6MM300A-N4LA
适配驱动器电压 V (rms) Typical Drive Voltages	380
直流母线电压 V (dc) Basic DC Bus Voltage	540
额定功率 kW Rated Output Power	3
额定转速 rpm Rated Speed	2000
最高转速 rpm Max. Speed	3000
额定转矩 Nm Rated Torque	14.3
堵转转矩 Nm Continuous Stall Torque	14.3
瞬时峰值扭矩 Nm Peak Torque	42.9
额定电流 A (rms) Rated Current	8.7
堵转电流 A (rms) Continuous Stall Current	8.7
瞬时峰值电流 A (rms) Peak Current	30
线反电势常数 V (rms) / K rpm Voltage Constant	109
转矩常数 Nm / A (rms) Torque Constant	1.80
线电阻 $\Omega$ @20° C Winding Resistance (Line-Line)	0.63
线电感 mH (typ.) Winding Inductance (Line-Line)	11.8 $\triangle$ <sub>3</sub>
转子惯量 kg m <sup>2</sup> Inertia	43.5x10 <sup>-4</sup>
电气时间常数 ms Electrical Time Constant	18.7 $\triangle$ <sub>3</sub>
极对数 Rotor Poles	5
编码器 Encoder	17位绝对值
轴向载荷 N Shaft Load - Axial	343
径向载荷 N Shaft Load - Radial (End of Shaft)	784
防护等级 Protection Class	IP65
绝缘等级 Insulation Class	F
重量 kg Weight	14.3

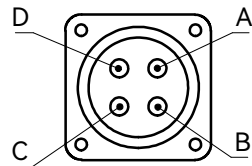
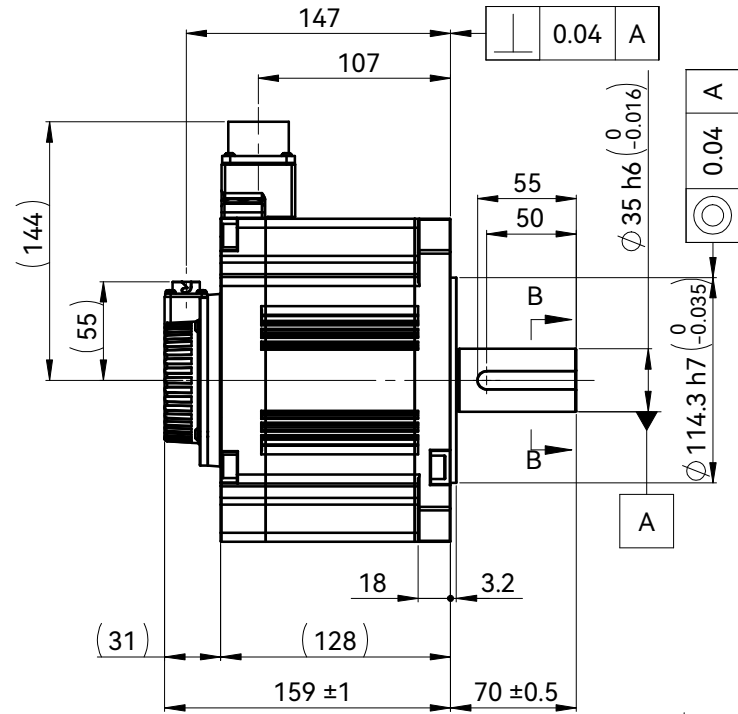
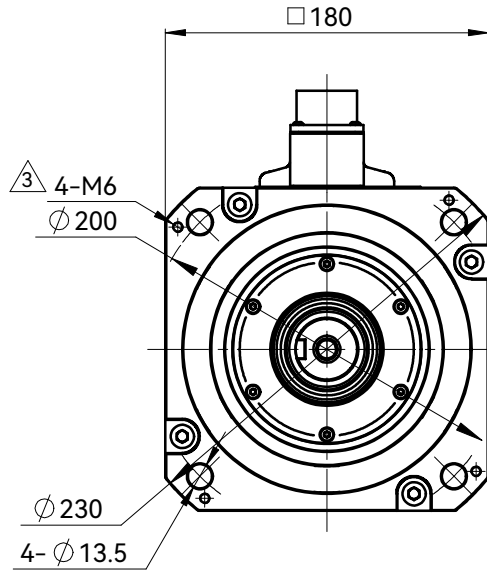

电机动力端 Motor Power Connection

针位 PIN No.	功能定义 Function
A	U
B	V
C	W
D	C.G

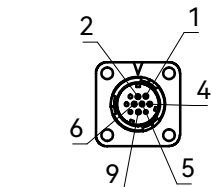

编码器端 Encoder Connection

针位 PIN No.	功能定义 Function
1	VCC
2	GND
3	-
4	BAT
5	+D
6	-D
7	-
8	-
9	BAT-
10	SHIELD

备注:  
notes

- GB/T 1096 键 B10x8x50 随电机一起包装, 但未安装。  
GB/T 1096 Key B10x8x50 is shipped with motor, but not installed.
- 防护等级IP65(除了轴上没装油封和非密封连接器情况)。  
IP65 (except Shaft without seal and non-sealed connectors)

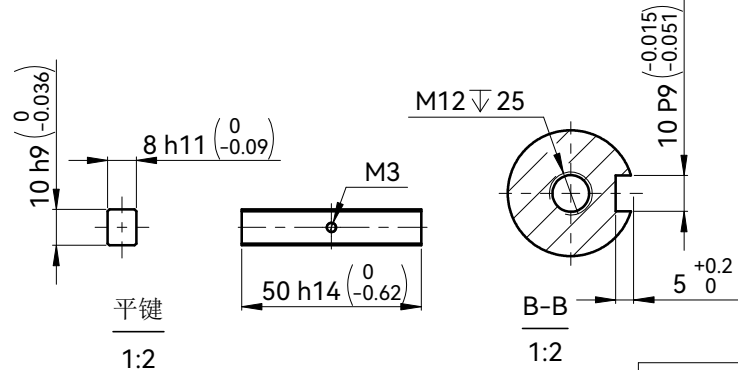

						客户回签			
$\triangle$ <sub>3</sub>	3	EC001966	ZML	063021	HCFA 浙江禾川科技股份有限公司				
$\triangle$ <sub>2</sub>	5	EC001380	ZML	120619	伺服电机(3kW)				
标记	处数	分区	更改文件号	签名	年月日	阶段	标记	重量	比例
设计	ZML	010919	标准化						1:4
审核									
工艺			批准			共 张	第 张		X6MM300A-N4LA