

电机规格 Motor Specifications

电机型号 Motor Model	X6MH200A-B4LA
适配驱动器电压 V (rms) Typical Drive Voltages	380
直流母线电压 V (dc) Basic DC Bus Voltage	540
额定功率 kW Rated Output Power	2
额定转速 rpm Rated Speed	2000
最高转速 rpm Max. Speed	3000
额定转矩 Nm Rated Torque	9.55
堵转转矩 Nm Continuous Stall Torque	9.55
瞬时峰值转矩 Nm Peak Torque	28.6
额定电流 A (rms) Rated Current	5.8
堵转电流 A (rms) Continuous Stall Current	5.8
瞬时峰值电流 A (rms) Peak Current	19
线反电势常数 V (rms) / K rpm Voltage Constant	110.6
转矩常数 Nm / A (rms) Torque Constant	1.83
线电阻 Ω @20° C Winding Resistance (Line-Line)	1.2 $\triangle 2$
线电感 mH (typ.) Winding Inductance (Line-Line)	18.6 $\triangle 2$
转子惯量 kg m ² Inertia	44.6X10 ⁻⁴
电气时间常数 ms Electrical Time Constant	15.2 $\triangle 2$
极对数 Rotor Poles	5
编码器 Encoder	17位绝对值
轴向载荷 N Shaft Load - Axial	343
径向载荷 N Shaft Load - Radial (End of Shaft)	784
防护等级 Protection Class	IP65
绝缘等级 Insulation Class	F
重量 kg Weight	17.4

制动器规格 Holding Brake Specifications

额定电压 DC(V) Rated Voltage	24±10%
额定电流 A Rated Current	1.04
静摩擦转矩(N.m) Static Friction Torque	> 74
吸引时间 ms Absorbing Time	≤120
释放时间 ms Releasing Time	≤30
释放电压 (V) Releasing Voltage	>0.5

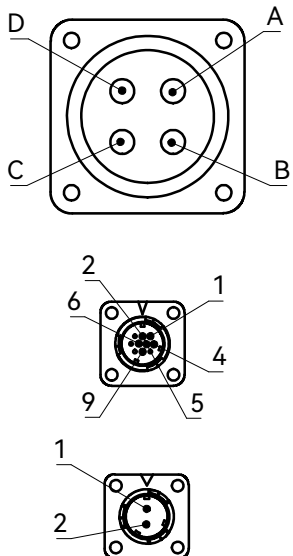
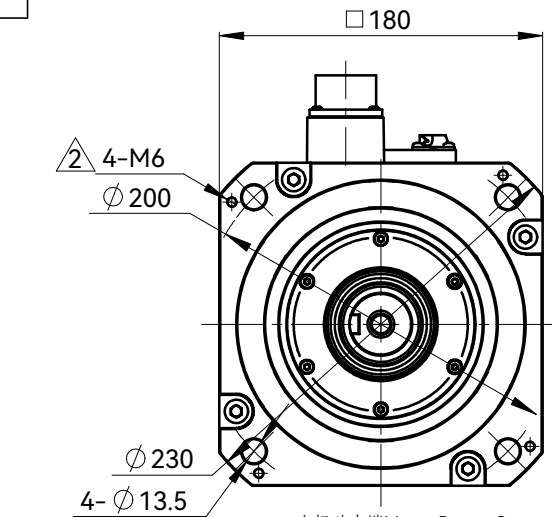

电机动力端 Motor Power Connection

针位 PIN No.	功能定义 Function
A	U
B	V
C	W
D	C.G

编码器端 Encoder Connection

针位 PIN No.	功能定义 Function
1	VCC
2	GND
3	-
4	BAT
5	+D
6	-D
7	-
8	-
9	BAT-
10	SHIELD

制动器端 Brake Connection

针位 PIN No.	功能定义 Function
1	BK
2	BK

备注:
notes

- GB/T 1096 键 B10x8x50 随电机一起包装, 但未安装。
GB/T 1096 Key B10x8x50 is shipped with motor, but not installed.
- 防护等级IP65(除了轴上没装油封和非密封连接器情况)。
IP65 (except Shaft without seal and non-sealed connectors)

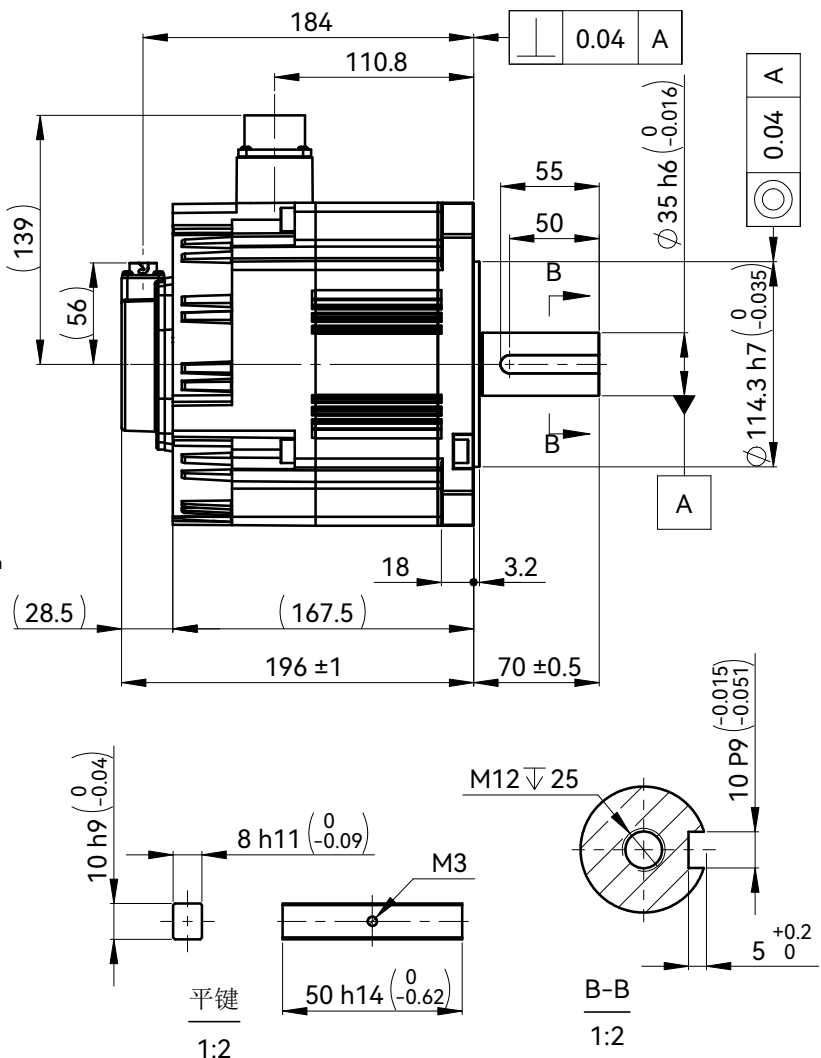

客户回签

				HCFA 浙江禾川科技股份有限公司		
$\triangle 2$	4	EC001966	ZML	062821	伺服电机(2kW带制动器)	
标记	处数	分区	更改文件号	签名	年月日	
设计	ZML	040920	标准化			阶段标记 重量 比例
审核						1:4
工艺			批准			共张 第张
						X6MH200A-B4LA