

### 电机规格 Motor Specifications

电机型号 Motor Model	X6MG550A-B4LD
适配驱动器电压 V (rms) Typical Drive Voltages	380
直流母线电压 V (dc) Basic DC Bus Voltage	540
额定功率 kW Rated Output Power	5.5
额定转速 rpm Rated Speed	1500
最高转速 rpm Max. Speed	3000
额定转矩 Nm Rated Torque	35
堵转转矩 Nm Continuous Stall Torque	35
瞬时峰值扭矩 Nm Peak Torque	87.5
额定电流 A (rms) Rated Current	19.5
堵转电流 A (rms) Continuous Stall Current	19.5
瞬时峰值电流 A (rms) Peak Current	51
线反电势常数V (rms) / K rpm Voltage Constant	120.5
转矩常数Nm / A (rms) Torque Constant	1.98
线电阻 $\Omega$ @20° C Winding Resistance (Line-Line)	0.28
线电感mH (typ.) Winding Inductance (Line-Line)	6.4
转子惯量kg m <sup>2</sup> Inertia	106.5X10 <sup>-4</sup>
电气时间常数ms Electrical Time Constant	22.9
极对数 Rotor Poles	5
编码器 Encoder	23位 绝对值
轴向载荷 N Shaft Load - Axial	588
径向载荷 N Shaft Load - Radial (End of Shaft)	1764
防护等级 Protection Class	IP65
绝缘等级 Insulation Class	F
重量 kg Weight	28.5

### 制动器规格 Holding Brake Specifications

额定电压 DC(V) Rated Voltage	24±10%
额定电流 A Rated Current	1.04
静摩擦转矩(N.m) Static Friction Torque	> 74
吸引时间 ms Absorbing Time	≤120
释放时间 ms Releasing Time	≤30
释放电压 (V) Releasing Voltage	>0.5

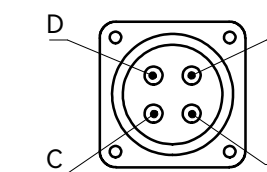
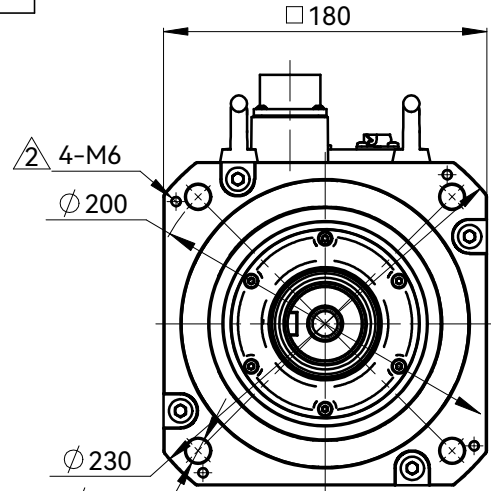

电机动力端 Motor Power Connection

针位 PIN No.	功能定义 Function
A	U
B	V
C	W
D	C.G

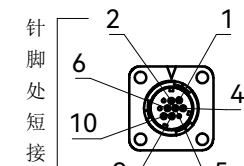

编码器端 Encoder Connection

针位 PIN No.	功能定义 Function
1	VCC
2	GND
3	-
4	BAT
5	+D0
6	-D0
7	-
8	-
9	-
10	SHIELD

制动器端 Brake Connection

针位 PIN No.	功能定义 Function
1	BK
2	BK

备注:

- notes
- GB/T 1096 键B12x8x90 随电机一起包装, 但未安装。  
GB/T 1096 Key B12x8x90 is shipped with motor, but not installed.
  - 防护等级IP65(除了轴上没装油封和非密封连接器情况)。  
IP65 (except Shaft without seal and non-sealed connectors)

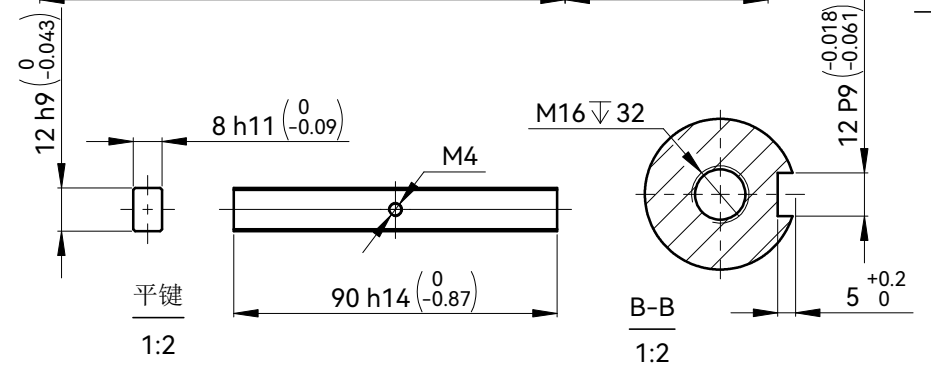
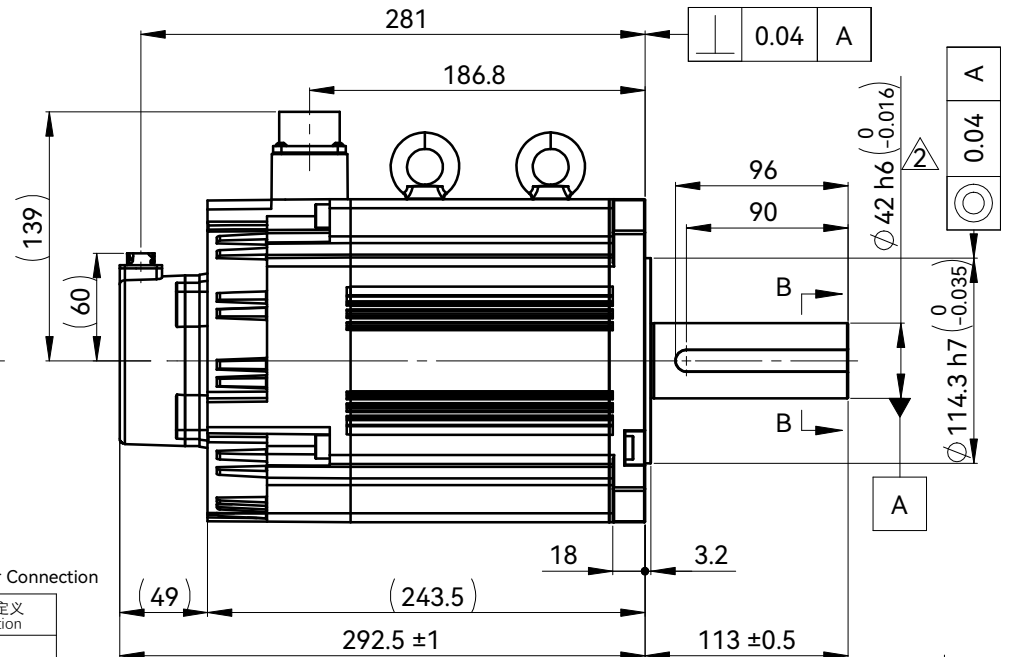

客户回签

HCFA 浙江禾川科技股份有限公司

伺服电机  
(5.5kW带制动器)

X6MG550A-B4LD

标记	6	EC001966	ZML	062821	阶段标记	重量	比例
设计	ZML	072220	标准化				1:4
审核					共张	第张	
工艺			批准				