

电机规格 Motor Specifications

电机型号 Motor Model	X6MG290A-N4LD
适配驱动器电压 V (rms) Typical Drive Voltages	380
直流母线电压 V (dc) Basic DC Bus Voltage	540
额定功率 kW Rated Output Power	2.9
额定转速 rpm Rated Speed	1500
最高转速 rpm Max. Speed	3000
额定转矩 Nm Rated Torque	18.6
堵转转矩 Nm Continuous Stall Torque	18.6
瞬时峰值扭矩 Nm Peak Torque	46.5 $\triangle 2$
额定电流 A (rms) Rated Current	10
堵转电流 A (rms) Continuous Stall Current	10
瞬时峰值电流 A (rms) Peak Current	26 $\triangle 2$
线反电势常数 V (rms) / K rpm Voltage Constant	121.6
转矩常数 Nm / A (rms) Torque Constant	2.01
线电阻 Ω @20° C Winding Resistance (Line-Line)	0.71
线电感 mH (typ.) Winding Inductance (Line-Line)	13.5 $\triangle 2$
转子惯量 kg m ² Inertia	47.2x10 ⁻⁴
电气时间常数 ms Electrical Time Constant	19.2 $\triangle 2$
极对数 Rotor Poles	5
编码器 Encoder	23位 绝对值
轴向载荷 N Shaft Load - Axial	490
径向载荷 N Shaft Load - Radial (End of Shaft)	1470
防护等级 Protection Class	IP65
绝缘等级 Insulation Class	F
重量 kg Weight	16

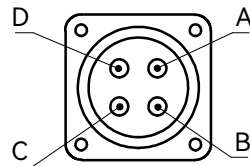
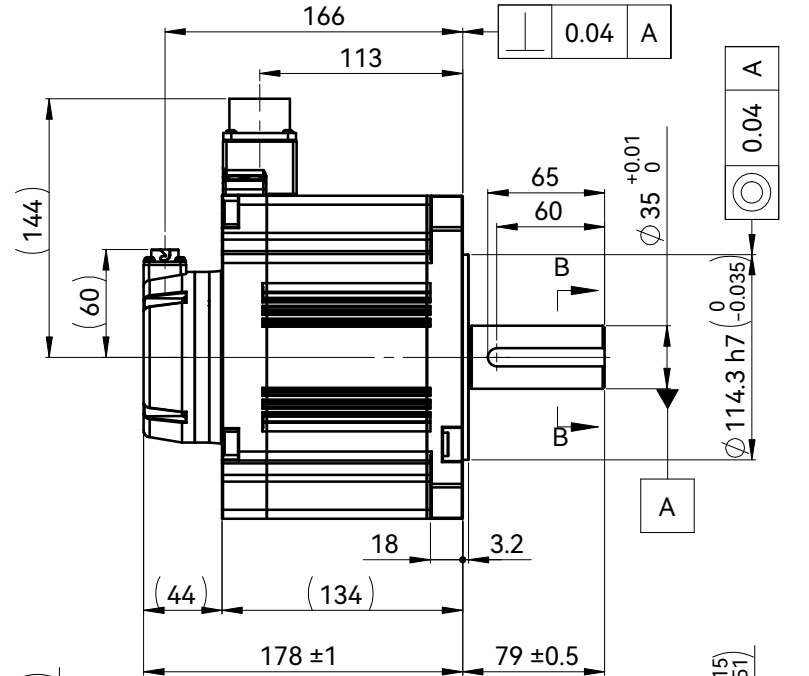
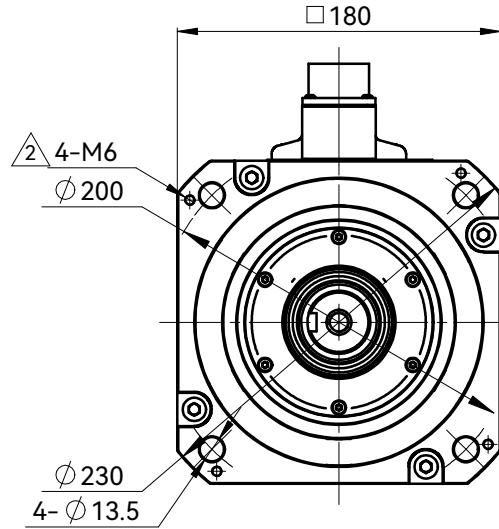

电机动力端 Motor Power Connection

针位 PIN No.	功能定义 Function
A	U
B	V
C	W
D	C.G

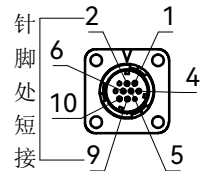

编码器端 Encoder Connection

针位 PIN No.	功能定义 Function
1	VCC
2	GND
3	-
4	BAT
5	+DO
6	-DO
7	-
8	-
9	-
10	SHIELD

备注:
notes

- GB/T 1096 键B10x8x60 随电机一起包装, 但未安装。
GB/T 1096 Key B10x8x60 is shipped with motor, but not installed.
- 防护等级IP65(除了轴上没装油封和非密封连接器情况)。
IP65 (except Shaft without seal and non-sealed connectors)

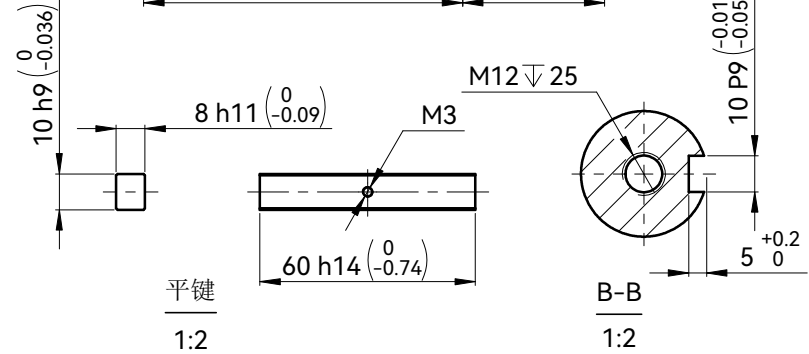

客户回签	
HCFA	浙江禾川科技股份有限公司
伺服电机(2.9kW)	
X6MG290A-N4LD	

$\triangle 2$	5	EC001966	ZML	063021					
标记	处数	分区	更改文件号	签名	年月日				
设计	ZML	010919	标准化			阶段标记	重量	比例	
审核								1:4	
工艺			批准			共张	第张		