

电机规格 Motor Specifications

| | |
|---|-----------------------|
| 电机型号 Motor Model | X6MG290A-B4LD |
| 适配驱动器电压 V (rms) Typical Drive Voltages | 380 |
| 直流母线电压 V (dc) Basic DC Bus Voltage | 540 |
| 额定功率 kW Rated Output Power | 2.9 |
| 额定转速 rpm Rated Speed | 1500 |
| 最高转速 rpm Max. Speed | 3000 |
| 额定转矩 Nm Rated Torque | 18.6 |
| 堵转转矩 Nm Continuous Stall Torque | 18.6 |
| 瞬时峰值转矩 Nm Peak Torque | 46.5 $\triangle 2$ |
| 额定电流 A (rms) Rated Current | 10 |
| 堵转电流 A (rms) Continuous Stall Current | 10 |
| 瞬时峰值电流 A (rms) Peak Current | 26 $\triangle 2$ |
| 线反电势常数 V (rms) / K rpm Voltage Constant | 121.6 |
| 转矩常数 Nm / A (rms) Torque Constant | 2.01 |
| 线电阻 Ω @20° C Winding Resistance (Line-Line) | 0.71 |
| 线电感 mH (typ.) Winding Inductance (Line-Line) | 13.5 $\triangle 2$ |
| 转子惯量 kg m^2 Inertia | 62.3×10^{-4} |
| 电气时间常数 ms Electrical Time Constant | 19.2 $\triangle 2$ |
| 极对数 Rotor Poles | 5 |
| 编码器 Encoder | 23位 绝对值 |
| 轴向载荷 N Shaft Load - Axial | 490 |
| 径向载荷 N Shaft Load - Radial (End of Shaft) | 1470 |
| 防护等级 Protection Class | IP65 |
| 绝缘等级 Insulation Class | F |
| 重量 kg Weight | 20.7 |

制动器规格 Holding Brake Specifications

| | |
|--------------------------------------|--------|
| 额定电压 DC(V) Rated Voltage | 24±10% |
| 额定电流 A Rated Current | 1.04 |
| 静摩擦转矩(N.m) Static Friction Torque | > 74 |
| 吸引时间 ms Absorbing Time | ≤120 |
| 释放时间 ms Releasing Time | ≤30 |
| 释放电压 (V) Releasing Voltage | >0.5 |

备注:
notes

- GB/T 1096 键B10x8x60 随电机一起包装, 但未安装。
GB/T 1096 Key B10x8x60 is shipped with motor, but not installed.
- 防护等级IP65(除了轴上没装油封和非密封连接器情况)。
IP65 (except Shaft without seal and non-sealed connectors)

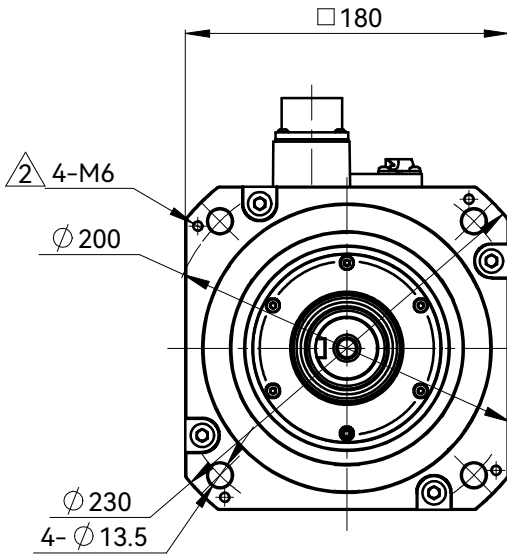

电机动力端 Motor Power Connection

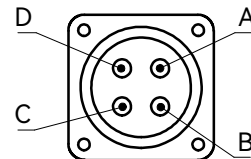

| 针位 PIN No. | 功能定义 Function |
|---------------|------------------|
| A | U |
| B | V |
| C | W |
| D | C.G |

编码器端 Encoder Connection

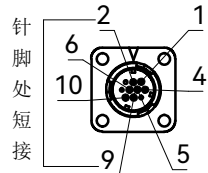

| 针位 PIN No. | 功能定义 Function |
|---------------|------------------|
| 1 | VCC |
| 2 | GND |
| 3 | - |
| 4 | BAT |
| 5 | +D0 |
| 6 | -D0 |
| 7 | - |
| 8 | - |
| 9 | - |
| 10 | SHIELD |

制动器端 Brake Connection

| 针位 PIN No. | 功能定义 Function |
|---------------|------------------|
| 1 | BK |
| 2 | BK |

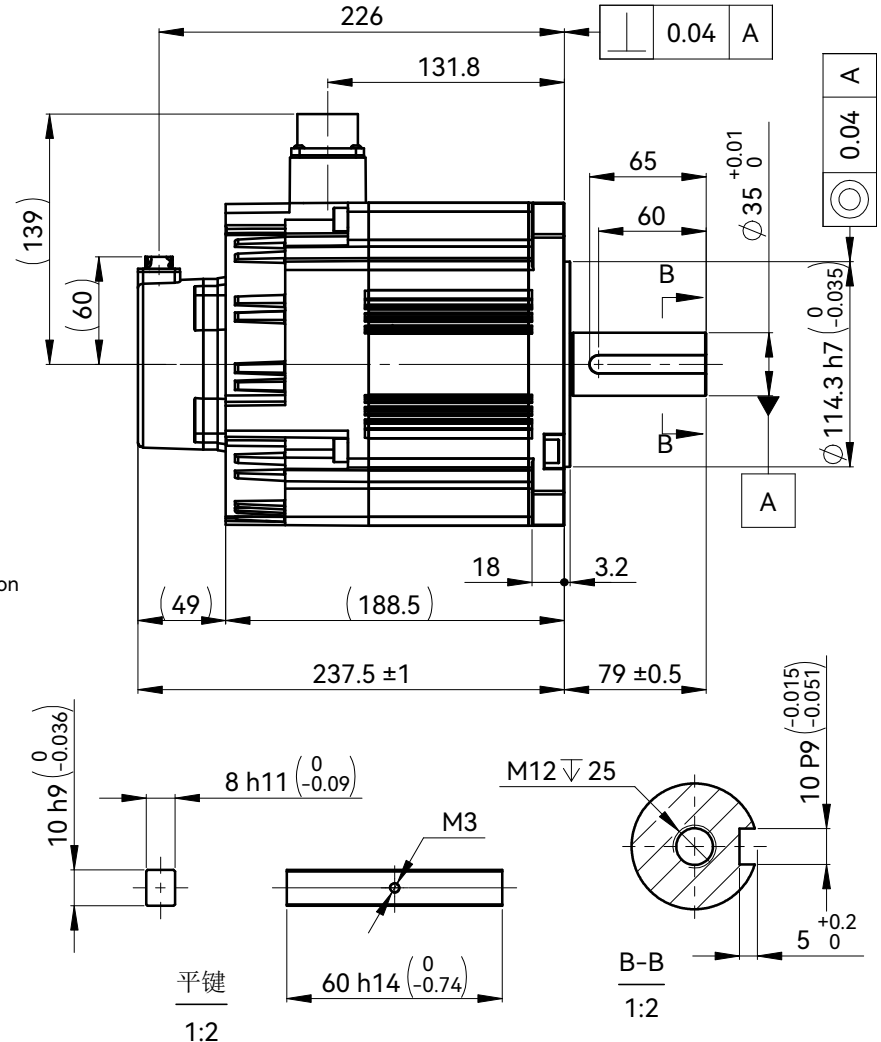

客户回签

| | | | | | | | |
|---------------|-----|----------|-------|--------|-------------------|---------------|----|
| | | | | | HCFA 浙江禾川科技股份有限公司 | | |
| $\triangle 2$ | 5 | EC001966 | ZML | 062821 | | | |
| 标记 | 处数 | 分区 | 更改文件号 | 签名 | 年月日 | | |
| 设计 | ZML | 040920 | 标准化 | | | 阶段标记 | 重量 |
| 审核 | | | | | | | 比例 |
| 工艺 | | | 批准 | | | 共张 第张 | |
| | | | | | | 1:4 | |
| | | | | | | X6MG290A-B4LD | |