

物料号	HPPD1420000
版本号	1.1
制作日期	2023年8月

Y7Smart 系列高阶伺服说明书 (EtherCAT 总线)

1 前言

感谢您使用禾川 Y7Smart 系列伺服驱动器，本说明书主要提供 Y7Smart 系列伺服 EtherCAT 总线型驱动器的规格尺寸、安装接线等相关使用说明信息。如需更详尽信息请扫描右侧二维码下载《Y7Smart 高阶伺服系统 EtherCAT 总线技术手册》。



驱动器包装清单如下表：

序号	名称	数量
1	Y7Smart 系列高阶驱动器	1
2	安全端子 *	1
	抱闸端子	1
	50pin 端子 (CN1 接口) *	1
3	Y7Smart 系列高阶伺服说明书 (EtherCAT 总线)	1
4	合格证	1

- 3kw 及以下机型配送电源输入接线端子 *1 和动力输出接线端子 *1
- 通用 N 型机种没有安全端子以及 50pin 端子 (CN1 接口)。
- 全功能 F 型机种包含第二编码器端子 (CN4 接口)
- 确认物件在运输途中是否具有损伤。
- 如果发现有问题，请联系经销商。

安全注意事项

安全图标

在接收检验、安装、配线、操作、维护及检查时，应随时注意以下安全注意事项。

对于忽视说明书记载内容，错误的使用本产品，而可能带来的危害和损害的程度按下列标识加以区分和说明。

	该标志表示「可能会发生导致死亡或重伤事故的危險」的内容
	该标志表示「可能会导致伤害或财产损失事故发生」的内容
	该图形表示禁止实施的「禁止实施」事项内容
	该图形表示必须实行的「强制实施」内容

⚠ 危险	
关于安装和配线	
	切勿将电机直接连接到商用电源。否则，会引发火灾、故障。
	请勿在电机、驱动器的周围放置可燃物。否则，会引发火灾事故。
	驱动器必须要用外箱保护，设置保护外箱时，外箱壁、其他机器和驱动器之间要使用说明书规定的距离。
	应安装在尘埃较少、不会接触到水、油等的地方。
	电机、驱动器安装在金属等非可燃物上。否则，会引发火灾事故。
	务必由专业电工进行接线作业。否则，会引发触电。
	电机、驱动器的 FG 端子必须接地。否则，会引发触电。
	必须先切断上位断路器，进行正确的接线。否则，可能会引发触电、受伤、故障、破损。
	电缆应确保连接好、通电部位须用绝缘物切实地做到绝缘。否则，会引发触电、火灾、故障。

⚠ 危险	
关于操作运行	
	请勿触摸驱动器内部。否则，会引发烧伤、触电事故。
	请勿让电缆线受到损伤、承受过大的外力、重压、受夹。否则，会引发触电、故障。
	切勿接触运转中的电机旋转部。否则，会引发受伤事故。
	请勿将电缆线浸在油和水中使用。否则，会引发触电、受伤、火灾事故。
	请勿用湿手进行接线和操作。否则，会引发触电、受伤、火灾事故。
	使用轴端带键槽的电机时，请勿裸手接触键槽。否则，会引发受伤事故。
	电机、驱动器、散热器的温度会升高，请勿触摸。否则，会引发烧伤或部件损伤事故。
	请勿用外部动力驱动电机。否则，会引发火灾事故。
关于其他使用上的注意事项	
	在地震发生后务必进行相关安全确认。否则，会引发触电、受伤、火灾事故。
	为防止发生地震时造成火灾及人身事故，应切实地进行设置和安装。
	务必在外部设置紧急停止电路，以确保紧急时能及时地停止运转、切断电源。否则，引发受伤、触电、火灾、故障、破损。
关于维护和点检	
	驱动器有危险高压部分，进行配线和点检工作时，必须切断电源放置使其放电后 (5 分钟以上) 进行。并且，绝对不允许对其进行分解。会引发触电事故。

⚠ 注意	
关于安装和配线	
	电机和驱动器要按指定的匹配组合。否则，会引发火灾、故障。
	不可直接触碰连接器端子。否则，会引发触电、故障。
	注意通风口不可堵塞，或异物进入。否则，会引发触电、火灾。
	试运行须在电机固定，并与其它机械系统分离状态下实施。动作确认后再次安装到机械系统上。否则，会引发受伤事故。
	遵守指定的安装方法、安装方向。否则，会引发受伤、故障。
	请根据设备本身的重量和产品的额定输出进行适当安装。否则，会引发受伤、故障。
关于操作和运转	
	请勿站在产品上、或在产品上放置重物。否则，会引发触电、受伤、故障、破损。
	禁止极端的增益调整及变更，会导致运作不稳定。否则，会引发故障、破损。
	请勿在受日光直接照射的地方使用。否则，会引发故障。
	请勿使电机及电机轴部受到较强的冲击。否则，会引发故障。
	电机内置制动器的作用是保持制动，禁止用在通常的制动场合。否则，会引发受伤、故障。
	停电后恢复供电时，有可能出现突然启动的情况，故请勿靠近机器。务必做好机器设定，以确保即使重启也可确保人身安全。
	不要使用有故障、破损的电机和驱动器。否则，会引发触电、火灾、受伤。
	请确认电源规格是否正常。引发故障发生原因。
	保持制动器不是确保机械安全的停止装置。请在机械侧设置确保安全用的停止装置。否则，会引发受伤事故。
	报警时，排除故障原因，确保安全后，解除报警，重启。否则，会引发受伤事故。
	制动器用继电器与紧急停止用断路器继电器需串联。否则，会引发受伤、故障。
关于搬运和保管	
	不能保存在雨水及水滴溅到的场所、有毒性气体及液体的地方。否则，会引发故障的。
	搬运时，切勿抓持电缆或电机轴部。否则，会引发受伤、故障。
	进行搬运时或安装作业时要以防落下或翻倒。否则，会引发受伤、故障。
	需长期保存时，请按本说明书记载的联系方法进行咨询。引发故障的原因。
	请保管在符合本说明书中规定保管环境的保管场所。否则，会引发故障。

⚠ 注意	
关于其他使用上的注意事项	
	废弃电池时，请将电池用胶带等进行绝缘处理，并根据有关部门的规定废弃处理。
	废弃时请作为工业废弃物处理。
关于维护和点检	
	除本公司外请勿进行拆卸修理工作。否则，会引发故障。
	主回路电源开关不要频繁的打开和关闭。否则，会引发故障。
	驱动器发生故障时，请切断电源和主回路电源。否则，会引发火灾事故。
	长时间不使用时务必切断主电源。因误动作等引发受伤事故。
关于维护和点检	
< 保证期限 >	
• 产品的保证期间为本公司制造月起 18 个月。但是，对对应制动器的电机，轴的加速、减速次数不超出使用寿命为前提。	
< 保证内容 >	
• 按照本说明书的正常使用状态下，在保证期间内，发生故障时为无偿修理。但是，即使在保证期间内有如下的故障发生时为有偿修理。 I 错误的使用方法，以及不适当的修理以及改造时 II 收货之后的摔落，以及不是公司品质原因的损伤。 III 超出产品规格使用该产品。 IV 火灾、地震、落雷、风灾与水灾、盐害、电压异常等其他灾害。 V 水、油、金属片、其他异物侵入。 • 保证范围为交付品本体，如由交付品的故障诱发的损害，判定为补偿范围外。	

2 产品型号说明

驱动器铭牌说明

Y7Smart 系列伺服驱动器侧面标签说明

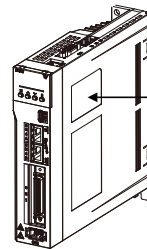
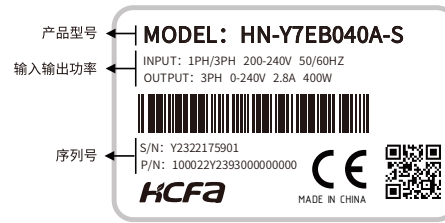

产品信息标签

型号说明

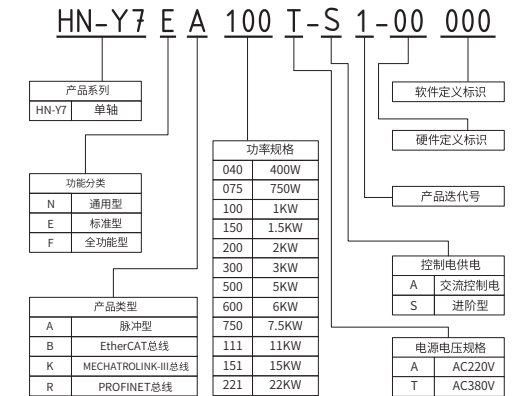

3 产品规格

环境规格

项目	规格
环境要求	开放式及室内使用
环境温度	0°C ~ 50°C (环境温度在 45 度以上每升高 5 度降额 10%)
保存温度	-20 ~ 65°C (最高温度保证: 80°C 72 小时 无结露)
使用环境温度	20% ~ 85%RH 以下 (无结露)
保管湿度	20% ~ 85%RH 以下 (无结露)
抗振性	5.88m/s ² (0.6G) 以下, 10-60Hz (避免在共振点连接使用)
抗冲击强度	加速度 100m/s ² 以下 (XYZ)
保护等级	IP20
清洁度	• 无腐蚀性气体、可燃性气体 • 无水、油、药剂飞溅
海拔高度	1000m 以下 (1000m ~ 2000m 时, 可降低额定值后使用)
污染等级	2
过电压类别	III
故障短路电流	5Ka
其他	无静电干扰、强电场、强磁场、放射线等

AC220V 基本规格

项目	规格					
型号 HN-Y7 □ □ ***A-S** ****	040	075	100	150	200	
最大适用电机容量 (kW)	0.4	0.75	1.0	1.5	2.0	
连续输出电流 (Arms)	2.8	5.5	7.6	11.6	15.6	
瞬时最大输出电流 (Arms)	9.3	16.9	17	28	39	
主回路	电源电压 (Arms)	单相 AC200 ~ 240V, 50/60Hz		三相 AC200 ~ 240V, 50/60Hz		
	电流 (Arms)	2.5	4.1	5.7	7.3	10
控制电源						
共用主回路电源						
再生电阻	内置电阻	电阻值 (Ω)	—	50	50	50
		容量 (W)	—	80	80	100
		容量 (W)	—	80	80	100
外置最小容许电阻值 (Ω)		40	40	35	20	20
过电压等级 III						

AC380V 基本规格

项目	规格										
型号 HN-Y7 □□□□□□□□	100	150	200	300	500	600	750	111	151	221	
最大适用电机容量 (kW)	1	1.5	2.0	3.0	5.0	6.0	7.5	11	15	22	
连续输出电流 (Arms)	4.7	5.4	8.4	11.9	16.5	20.8	25.7	28.1	37.2	52	
瞬时最大输出电流 (Arms)	16.9	17	24	31	44	52	65	70	88	105	
主回路	三相 AC330 ~ 440V、50/60Hz										
电源电压 (Arms)	2.9	4.3	5.8	8.6	14.5	17.4	21.7	23.4	29.6	43.4	
电流 (Arms)	共用主回路电源 三相 AC330 ~ 440V、50/60Hz										
控制电源	内阻电阻 (Ω)										
再生电阻	50	50	50	40	25	20	20	—	—	—	
容量 (W)	80	80	80	100	100	100	100	—	—	—	
外置最小容许电阻值 (Ω)	40	40	40	35	25	20	20	15	10	10	
过电压等级	III										

注意

- 以通常的额定负载率使用外置再生电阻器时，当电阻器的温度将达到 200°C ~ 300°C，请务必降低额定值后再使用。关于电阻器的负载特性，请向生产厂家咨询。
- 为确保安全，建议使用带温控开关的外置再生电阻器。

4 伺服驱动器安装及尺寸说明

Y7Smart 驱动配置表

伺服驱动器 (AC220V)	SIZE A		SIZE B		SIZE D					
	HN-Y7 □□□□04A-S	HN-Y7 □□□□075A-S	HN-Y7 □□□□100A-S	HN-Y7 □□□□200A-S	HN-Y7 □□□□150A-S	HN-Y7 □□□□200A-S	HN-Y7 □□□□221T-S			
伺服驱动器 (AC380V)	SIZE C		SIZE D		SIZE E		SIZE F		SIZE G	
	HN-Y7 □□□□100T-S	HN-Y7 □□□□200T-S	HN-Y7 □□□□300T-S	HN-Y7 □□□□500T-S	HN-Y7 □□□□600T-S	HN-Y7 □□□□750T-S	HN-Y7 □□□□111T-S	HN-Y7 □□□□151T-S	HN-Y7 □□□□221T-S	HN-Y7 □□□□221T-S

Y7Smart 系列驱动器安装尺寸

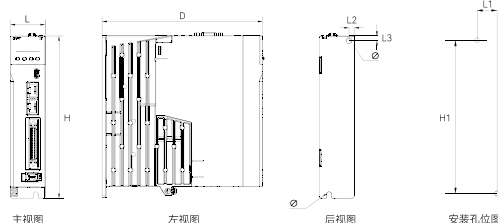

结构	SIZE A	SIZE B	SIZE C	SIZE D (AC220V)	SIZE D (AC380V)	SIZE E	SIZE F	SIZE G
L(mm)	37.0	47.0	55.0	70.0	90.0	90.0	194.0	
H(mm)	172.0	172.0	175.0	175.0	182.8	243.3	240.0	
D(mm)	170.0	170.0	180.0	180.0	192.5	205.2	205.0	
L1(mm)	21.3	31.3	39.7	54.7	76.0	76.0		
L2(mm)	5.5	5.5	5.5	5.5	7.0	7.0		
L3(mm)	5.0	4.5	5.0	5.0	6.0	6.0		
H1(mm)	162.8	162.8	163.0	163.0	168.0	227.5		
孔径 (φ)	5.5	5.5	5.5	5.5	6.0	6.0		
螺丝孔	2-M5	2-M5	2-M5	2-M5	3-M5	4-M5		
锁紧扭矩 (Nm)	3.5N·M	3.5N·M	3.5N·M	3.5N·M	3.5N·M	3.5N·M		
重量 (kg)	0.76	1.01	1.21	1.45	1.5	2.2	3.6	8.77

机柜安装说明

注意事项

- 安装伺服驱动器时，不可封住其吸排气孔，也不可将其倾斜放置，否则会造成故障。
- 为了使散热风扇能够有比较低的风阻，以有效排出热量，安装一台或多台驱动器时，请依据安装间隔距离建议值。
- 请避免上下排列使用，因下排驱动器在运转时所产生的热气上升，容易造成上排驱动器不必要的温度增加。

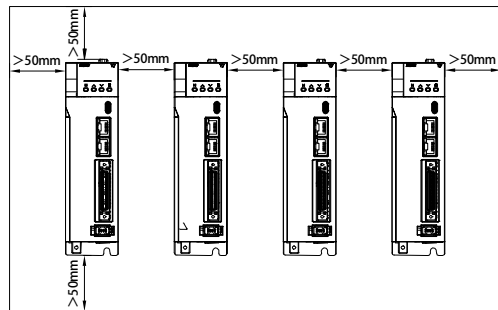

注) 图中驱动器安装间隔距离 50mm 是按照在最高 55°C 的条件下，无外界通风的情况。具体取决于客户的散热条、比如箱体温度、通风条件等，如能保证驱动器的使用环境温度低于 55°C，间隔距离可以低于 50mm。

结构安装说明

注意事项

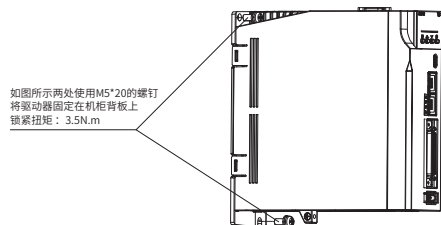

大功率驱动安装说明

此说明适用于 HN-Y7 □□□□111T-S、HN-Y7 □□□□151T-S、HN-Y7 □□□□221T-S 机型，用户可以根据设备使用需要选择采用壁挂式安装或者穿墙式安装。

壁挂安装:

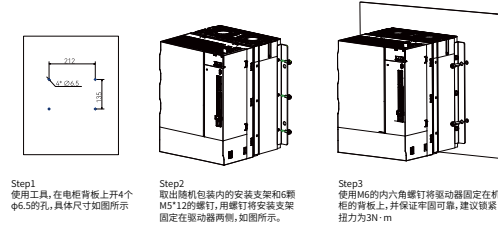

穿墙安装:

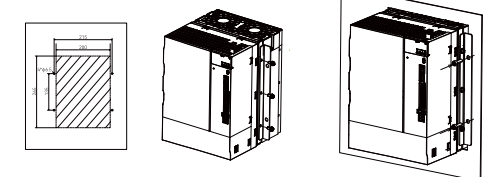

Step1 使用工具，在电柜背板上开 4 个 φ6.5mm 的孔，具体尺寸如图所示

Step2 取出随机包装内的安装支架和 6 颗 M5*12 的螺钉，用螺钉将安装支架固定在驱动器两侧，如图所示。

Step3 将驱动器插入孔洞，并使用 M6 的内六角螺钉将驱动器固定在机柜的背板上，并确保牢固可靠，建议锁紧扭力为 3N·m

5 配线

线缆要求

端子	名称	型号 HN-Y7 □□□□□□ A-S				
		040	075	100	150	200
LC1、LC2	控制电源输入端子	—				
L1、L2、L3	主回路电源输入端子	0.82mm ² (AWG18)		1.318mm ² (AWG16)		2.075mm ² (AWG14)
U、V、W	伺服电机连接端子	0.82mm ² (AWG18)		1.318mm ² (AWG16)		2.627mm ² (AWG13)
B1、B2	外置再生电阻连接端子	根据外置电阻的实际功率确定，请咨询电阻厂商或者我司技术人员				
	接地端子	> 2.075mm ² (<AWG14)				

端子	名称	型号 HN-Y7 □□□□□□ T-S															
		100	150	200	300	500	600	750	111	151	221						
LC1、LC2	控制电源输入端子	—															
L1、L2、L3	主回路电源输入端子	0.82mm ² (AWG18)		1.646mm ² (AWG15)		3.332mm ² (AWG12)		4.17mm ² (AWG11)		5.26mm ² (AWG10)		6.63mm ² (AWG9)		8.37mm ² (AWG8)		10.55mm ² (AWG7)	
U、V、W	伺服电机连接端子	1.026mm ² (AWG17)		1.646mm ² (AWG15)		2.627mm ² (AWG12)		3.332mm ² (AWG11)		4.17mm ² (AWG11)		6.63mm ² (AWG9)		8.37mm ² (AWG8)		10.55mm ² (AWG7)	
B1、B2	外置再生电阻连接端子	根据外置电阻的实际功率确定，请咨询电阻厂商或者我司技术人员															
	接地端子	> 2.075mm ² (<AWG14)															

注 1) 如有穿管、线槽等封闭，或者现场环境温度较高 (>55°C) 时，请将线轨规格加大一档。

连接器型端子驱动器端口定义及配线说明

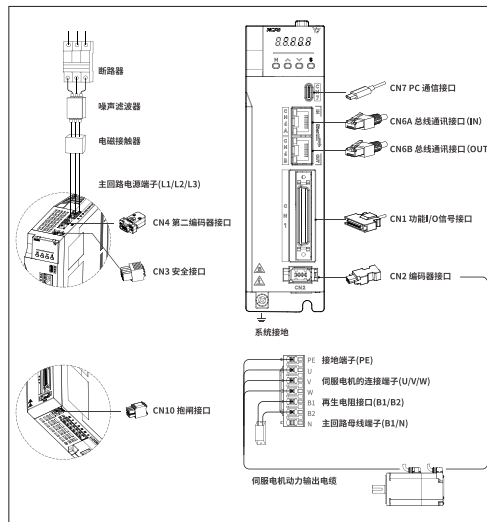

栅栏型端子驱动器端口定义及配线说明

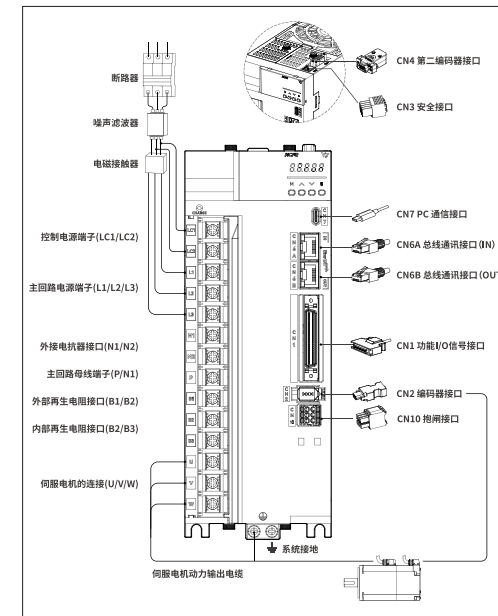

CN1 端子排列

2	SG	GND	1	SG	GND	27	OUT4+	高速输出	26	OUT3-	输出信号可分配
4	SEN	SEN 信号输入	3	PL1	集电极开路指令用内部电源 12V	29	OUT1+	输出信号可分配	28	OUT4-	高速输出
6	SG	GND	5	V-REF	模拟量速度输入指令	31	ALM+	伺服警报输出	30	OUT1-	输出信号可分配
8	空	空	7	空	空	33	PAO	编码器分频脉冲输出 A 相	32	ALM-	伺服警报输出
10	SG	GND	9	T-REF	模拟量转矩指令输入	35	PBO	编码器分频脉冲输出 B 相	34	/PAO	编码器分频脉冲输出 A 相
12	空	空	11	空	空	37	OUT5+	高速输出	36	/PBO	编码器分频脉冲输出 B 相
14	CLR	集电极清除输入	13	PL2	集电极开路指令用内部电源 12V	39	DAC0	模拟量输出 1	38	OUT5-	高速输出
16	空	空	15	空	空	41	SI1	探针 1	40	SI0	回原信号驱动输入
18	PL3	集电极开路指令用	17	空	空	43	SI3	禁止反转侧驱动输入	42	SI2	禁止正转侧驱动输入
20	/PCO	编码器分频脉冲输出 C 相	19	PCO+	编码器分频脉冲输出 C 相	45	空	空	44	SI4	探针 2
22	空	空	21	空	空	47	DI (COM)	外部 24V 电源输入	46	空	空
24	空	空	23	空	空	49	OCZ	Z 信号集电极输出	48	DAC1	模拟量输出 2
			25	OUT3+	输出信号可分配				50	TH	外部温度检测

注 1) 仅全功能 F 型支持高速输出、模拟量输入及脉冲分频输出。
注 2) 通用 N 型无 CN1。

编码器信号 (CN2)

接口布局	Pin1	Pin2	Pin3	Pin4	Pin5	Pin6	壳体
	编码器电源 +5V	编码器电源 0V	-	-	串行数据 (+)	串行数据 (-)	-

安全功能信号 (CN3)

驱动器 STO 接口	STO 安全接头	接口布局					
		EDM+ 8 7 EDM- HWBB2+ 6 5 HWBB2- HWBB1+ 4 3 HWBB1- NC- 2 1 NC+					
Pin1	Pin2	Pin3	Pin4	Pin5	Pin6	Pin7	Pin8
NC+	NC-	HWBB1-	HWBB1+	HWBB2-	HWBB2+	EDM-	EDM+
-	-	输入 1-	输入 1+	输入 2-	输入 2+	输出 -	输出 +

第二编码器 (CN4)

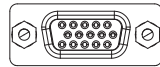

引脚	增量式 ABZ 编码器带差分霍尔传感器	正弦编码器带差分霍尔传感器和 Z 信号	BISS 编码器	多摩川编码器
1	+5V 输出 电流输出 ≤ 300mA	+5V 输出 电流输出 ≤ 300mA	+5V 输出 电流输出 ≤ 300mA	+5V 输出 电流输出 ≤ 300mA
2	0V 输出	0V 输出	0V 输出	0V 输出
3	霍尔 U+	霍尔 U+	-	-
4	霍尔 U-	霍尔 U-	-	-
5	霍尔 V+	霍尔 V+	-	-
6	增量编码器 A-	正弦编码器 Sin -	BISS-C CLK-	Serial DATA-
7	增量编码器 B-	正弦编码器 Cos -	BISS-C DATA-	-
8	增量编码器 Z-	增量编码器 Z-	-	-
9	霍尔 W+	霍尔 W+	-	-
10	霍尔 V-	霍尔 V-	-	-
11	增量编码器 A+	正弦编码器 Sin +	BISS-C CLK+	Serial DATA+
12	增量编码器 B+	正弦编码器 Cos +	BISS-C DATA+	-
13	增量编码器 Z+	-	-	-
14	霍尔 W-	霍尔 W-	-	-
15	温度传感器信号	温度传感器信号	温度传感器信号	温度传感器信号
壳体	屏蔽	屏蔽	屏蔽	屏蔽

通讯接口 (CN6)

接口布局	Pin1	Pin2	Pin3	Pin4	Pin5	Pin6	Pin7	Pin8
	TD+	TD-	RD+	-	-	RD-	-	-

抱闸接口 (CN10)

驱动器 STO 接口	STO 安全接头	接口布局			
		T- 6 5 T+ BK- 4 3 BK+ 0V 2 1 24V			
Pin1	Pin2	Pin3	Pin4	Pin5	Pin6
24V	0V	BK+	BK-	T+	T-
24V 电源				伺服刹车线	
				温控 +	
				温控 -	

注 1) : 刹车 DC24V 电源请勿和 CN1 控制回路电源共用, NTC 规格为 KTY84

输入输出信号的连接示例 (总线型)

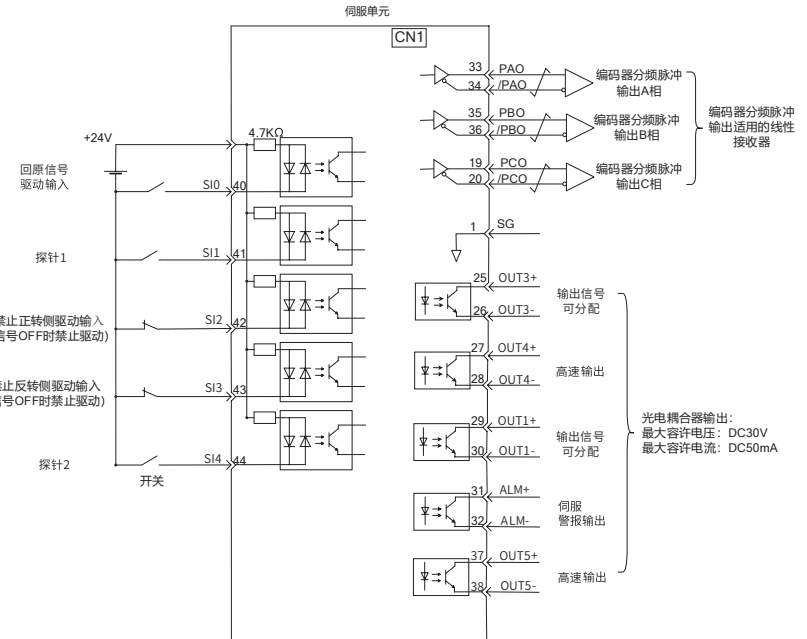

抱闸接线

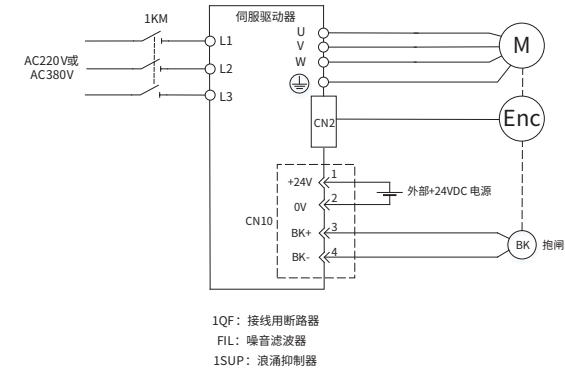

6 Y7Smart 系列伺服报警简表

故障报警原因及处理措施

报警编号: 报警名称 (报警内容)	原因	确认方法	处理措施
A.020: 参数和校验异常 (伺服单元内部参数的数据异常)	电源电压瞬时下降	测量电源电压	将电源电压设定在规格范围内, 进行参数设定值的初始化 (Fn005)。
	在参数写入过程中关闭了电源	确认断电的时间	在进行参数设定值的初始 (Fn005) 后, 再次输入参数。
	参数的写入次数超过了最大值	确认是否从上位装置频繁地进行了参数变更	可能是伺服单元故障。 更换伺服单元。 改变参数写入方法。
	因来自 AC 电源、接地以及静电等的噪音而产生了误动作 由于气体、水滴或切削油等导致伺服单元内部的部件发生了故障	多次接通电源后仍发生报警时, 有可能是噪音的原因 确认安装环境	采取防止噪音干扰的措施。 可能是伺服单元故障。 更换伺服单元。
A.021: 参数格式化异常 (伺服单元内部参数的数据形式异常)	与发生报警的伺服单元的软件版本相比, 写入参数的软件版本更新	利用 Fn012 确认软件版本是否相同。如果版本不同, 有可能导致报警发生	写入软件版本、型号相同的其他伺服单元的参数, 然后再接通电源。
	伺服单元故障	—	可能是伺服单元故障。 更换伺服单元。
A.022: 系统和校验异常 (伺服单元内部参数的数据异常)	电源电压瞬时下降	测量电源电压	可能是伺服单元故障。 更换伺服单元。
	在设定辅助功能的过程中关闭了电源	确认断电的时间	可能是伺服单元故障。 更换伺服单元。
	伺服单元故障	多次接通电源后仍发生报警时, 有可能是发生了故障	可能是伺服单元故障。 更换伺服单元。
A.030: 主回路检出故障	伺服单元故障	—	可能是伺服单元故障。更换伺服单元。
	伺服单元容量与伺服电机容量不匹配	确认伺服单元与伺服电机的容量及组合	使伺服单元与伺服电机的容量相互匹配。
A.040: 参数设定异常 (超过设定范围)	伺服单元故障	—	可能是伺服单元故障。 更换伺服单元。
	在参数设定范围外	确认变更后的参数的设定范围	使变更后的参数为设定范围内的值。
	电子齿轮比的设定值在设定范围外	确认电子齿轮比是否为 $0.001 < (Pn78C/Pn78E) < 4000$	将电子齿轮比设为 $0.001 < (Pn78C/Pn78E) < 4000$ 。
A.041: 分频脉冲输出设定异常	编码器分频脉冲数 (Pn212) 不满足设定范围和设定条件	确认 Pn212	将 Pn212 设定为适当的值。
	由于变更了电子齿轮比 (Pn78C/Pn78E) 或伺服电机, 使得程序 JOG 运行 (Fn004) 的速度不符合设定范围	确认检出条件公式 *1 是否成立	减小电子齿轮比 (Pn78C/Pn78E) 的值。
A.042*1: 参数组合异常	由于变更了程序 JOG 移动速度 (Pn533), 导致程序 JOG 运行 (Fn004) 的速度不符合设定范围	确认检出条件公式 *1 是否成立	增大程序 JOG 移动速度 (Pn533) 的值。
	由于变更了电子齿轮比 (Pn78C/Pn78E) 或伺服电机, 高级自动调谐的移动速度不符合设定范围	确认检出条件公式 *1 是否成立	减小电子齿轮比 (Pn78C/Pn78E) 的值。
A.044: 半闭环 / 全闭环参数设定故障	全闭环模块与 Pn002.3 的设定不符	确认 Pn002.3 的设定	使全闭环模块与 Pn002.3 的设定相符。
A.050: 组合错误 (在可组合的电机容量范围以外)	伺服单元容量与伺服电机的容量不匹配	确认为 $\frac{1}{4} \leq \frac{\text{电机容量}}{\text{伺服单元容量}} \leq 4$	使伺服单元与伺服电机的容量相互匹配。
	编码器故障	与别的伺服电机更换, 确认警报不再发生	更换伺服电机 (编码器)。
A.051: 产品在支持警报	在伺服单元上连接了不支持的串行转换单元、编码器、外部编码器	确认产品的组合	变更为配套的组合。
A.0b0: 伺服 ON 指令无效警报	执行了电机通电辅助功能后, 从外部输入了伺服 ON (/S-ON) 信号	—	再次接通伺服单元的电源或者执行软件复位。

报警编号: 报警名称 (报警内容)	原因	确认方法	处理措施
A.100: 过电流检出 (过电流流过了功率晶体管或散热片过热)	主回路电缆接线错误或接触不良	确认接线是否正确 详情参照	修改接线。
	主回路电缆内部发生短路或接地故障	确认电缆的 UVW 相间、UVW 与接地之间是否发生短路。	电缆有可能短路。 更换电缆。
	伺服电机内部发生短路或接地短路	确认电机端子的 UVW 相间、UVW 与接地之间是否发生短路。	有可能是伺服电机故障。 更换伺服电机。
	伺服单元内部发生短路或接地	确认伺服单元的伺服电机连接端子的 UVW 相间、UVW 与接地之间是否发生短路。详情参照	可能是伺服单元故障。 更换伺服单元。
	再生电阻接线错误或接触不良	确认接线是否正确	修改接线。
	动态制动器 (因 DB、伺服单元而发生的紧急停止) 的使用频度高、或发生了 DB 过载警报	通过 DB 电阻功耗 (Un00B) 来确认 DB 的使用频率。或者利用警报记录的显示 (Fn000) 来确认是否发生了 DB 过载警报 A.730、A.731。	变更伺服单元的选型、运行方法和机构, 以降低 DB 的使用频率。
	再生电阻值过高, 超过了再生处理能力	利用再生负载率 (Un00A) 来确认再生电阻的使用频率	考虑运行条件和负载, 再次探讨再生电阻值。
	伺服单元的再生电阻值过小	利用再生负载率 (Un00A) 来确认再生电阻的使用频率	将再生电阻值变更为伺服单元最小容许电阻值以上的值。
	在伺服电机停止时或低速运行的承受了高负载	确认运行条件是否在伺服驱动器的规格范围以外。	减轻伺服电机承受的负载或以较高的运行速度运行。
	因噪音而产生误动作	改善接线、安装等噪音环境, 确认有无效效果	采取防止噪音的措施, 如正确进行 FG 的接线等。另外, FG 的电线尺寸请使用和“伺服单元主回路电线尺寸”相同的电线。
A.300: 再生故障	伺服单元故障	—	再次接通电源。仍然发生报警时, 有可能是伺服单元故障。 更换伺服单元。
	将再生电阻容量 (Pn600) 设为“0”以外的值, 却没有外置再生电阻器	确认外置再生电阻器的连接和 Pn600 的值。	连接外置再生电阻器, 或在不需要再生电阻器时, 将 Pn600 设定为 0。
	没有外置再生电阻器, 且伺服单元电源端子 B2-B3 的跨接线脱落	确认电源端子跨接线的接线	正确连接跨接线。
	外置再生电阻器的接线不良、脱落或断线	确认外置再生电阻器的接线	对外置再生电阻器进行正确接线。
A.320: 再生过载	电源电压超过规格范围	测量电源电压	在不接通主回路电源的状态下, 再次接通控制电源, 仍然发生报警时, 有可能是伺服单元故障。更换伺服单元。 将电源电压设定在规格范围内。
	外置再生电阻值或再生电阻容量不足, 或者处于连续再生状态	再次确认运行条件或容量	变更再生电阻值、再生电阻容量再次进行运行条件的调整。
	连续承受负载, 处于连续再生状态	确认向运行中的伺服电机施加的负载	再次探讨包括伺服、机械、运行条件在内的系统。
	参数 Pn600 中设定的容量小于外置再生电阻的容量	确认再生电阻器的连接和 Pn600 的值	校正参数 Pn600 的设定值。
A.330: 主回路电源接线错误 * 在接通主回路电源时检出	外置再生电阻值过大	确认再生电阻值是否正确	将其变更为正确的电阻值和容量。
	伺服单元故障	—	可能是伺服单元故障。 更换伺服单元。
	伺服单元内部的电源电压过高, 再生电阻器断线	用测量仪器测量再生电阻器的电阻值	使用伺服单元内置的再生电阻器时, 更换伺服单元。 使用外置再生电阻器时, 更换再生电阻器。
	设定 AC 电源输入时, 输入了 DC 电源	确认电源是否为 DC 电源	使电源的设定值与使用的电源保持一致。
	设定 DC 电源输入时, 输入了 AC 电源	确认电源是否为 AC 电源	使电源的设定值与使用的电源保持一致。
	将再生电阻容量 (Pn600) 设为“0”以外的值, 却没有外置再生电阻器	确认外置再生电阻器的连接和 Pn600 的值	连接外置再生电阻器, 或在不需要外置再生电阻器时, 将 Pn600 设定为 0。
A.400: 过电压 (通过伺服单元内部的主回路电源部检出过电压)	上述以外容量的伺服单元电源端子 B2-B3 的跨接线脱落	确认电源端子跨接线的接线	正确连接跨接线。
	伺服单元故障	—	可能是伺服单元故障。 更换伺服单元。
	· AC200V 用伺服单元、AC 电源电压在 290V 以上, 或者 AC400V 用伺服单元检出了 AC580V 以上的电源电压	测量电源电压	将 AC/DC 电源电压调节到产品规格范围内。
	· AC200V 用伺服单元、DC 电源电压在 410V 以上, AC400V 用伺服单元检出了 830V 以上的 DC 电源电压	测量电源电压	将 AC/DC 电源电压调节到产品规格范围内。
	电源处于不稳定状态、或受到了雷击的影响	测量电源电压	改善电源状况, 设置浪涌抑制器等后再次接通电源, 仍然发生报警时, 有可能是伺服单元故障。更换伺服单元。
	在 AC 电源电压高于规格范围时进行了加减速	确认电源电压和运行中的速度、转矩	将 AC 电源电压调节到产品规格范围内。
A.410: 欠电压 (通过伺服单元内部的主回路电源部检出欠电压)	外置再生电阻值比运行条件大	确认运行条件和再生电阻值	考虑运行条件和负载, 再次探讨再生电阻值。
	在容许转动惯量比以上的状态下运行	确认转动惯量比在容许转动惯量比以内	延长减速时间, 或减小负载。
	伺服单元故障	—	在不接通主回路电源的状态下, 再次接通控制电源, 仍然发生报警时, 有可能是伺服单元故障。更换伺服单元。
	AC200V 用伺服单元、AC 电源电压在 120V 以下, AC400V 用伺服单元、AC 电源电压在 220V 以下	测量电源电压	将电源电压调节到正常范围。
	运行中电源电压下降	测量电源电压	增大电源容量。
	发生瞬时停电	测量电源电压	如果变更了瞬时停电保持时间 (Pn509), 则设定为较小的值。 更换伺服单元, 连接电抗器后再使用伺服单元。
A.450: 主回路电容过电压	伺服单元的保险丝熔断	—	可能是伺服单元故障。 更换伺服单元。
	伺服单元故障	—	可能是伺服单元故障。 更换伺服单元。

警报编号: 警报名称 (警报内容)	原因	确认方法	处理措施
A.510: 过速 (电机速度在最高速度以上)	电机接线的 U、V、W 相序错误	确认伺服电机的接线	确认电机接线是否有问题。
	指令输入值超过了过速值	确认输入指令	降低指令值, 或调整增益。
	电机速度超过了最高速度	确认电机速度的波形	降低速度指令输入增益, 调整伺服增益, 或调整运行条件。
A.511: 分频脉冲输出过速	伺服单元故障	—	可能是伺服单元故障。 更换伺服单元。
	分频脉冲的输出频率过大, 超过了限制值 电机速度过高, 分频脉冲的输出频率超过了限制值	确认分频脉冲的输出设定 确认分频脉冲的输出设定和电机速度	降低速度指令脉冲数 (Pn212) 的设定。 降低电机速度。
A.520: 振动警报	检出电机速度异常振动	确认电机的异常声音和运行时的速度、转矩波形	降低电机速度。 或降低速度环增益 (Pn100)。
	转动惯量比 (Pn103) 的值比实际值大或进行了大的变动	确认转动惯量比	正确地设定转动惯量比 (Pn103)。
A.521: 高级自动调谐警报 (在单参数调谐、EasyFFT、免调整功能中检出了振动)	在使用免调整功能时电机振动很大	确认电机速度的波形	减小负载, 使其在容许转动惯量比以下, 或提高免调整值设定 (Fn200) 的负载值, 或降低刚性值。
	在执行单参数调谐、EasyFFT 过程中, 电机振动很大	确认电机速度的波形	实施各功能操作步骤中的处理措施。
A.710: 过载 (瞬时最大负载) A.720: 过载 (连续最大负载)	电机接线、编码器接线不良或连接不良	确认接线	确认电机接线、编码器接线是否有问题。
	电机运行超过了过载保护特性 由于机械性因素而导致电机不驱动, 造成运行时的负载过大	确认电机的过载特性和运行指 确认运行指令和电机速	重新探讨负载条件、运行条件或者重新研讨电机容量。 改善机械性因素。
A.730: A.731: DB 过载 (检出动态制动器的功耗过大)	伺服单元故障	—	可能是伺服单元故障。 更换伺服单元。
	电机在被外力驱动	确认运行状态	不要通过外力驱动电机。 尝试以下措施 · 降低伺服电机的指令速度。 · 减小转动惯量比。 · 减少 DB 停止的次数。
A.740: 冲击电流限制电阻过载 (主回路电源接通频率过高)	DB 停止时的旋转能量超过 DB 电阻的容量	通过 DB 电阻功耗 (Un00B) 来确认 DB 的使用频率	减少主回路电源的 ON/OFF 次数。
	伺服单元故障	—	可能是伺服单元故障。 更换伺服单元。
A.7A0: 散热片过热 (伺服单元的温度超过了 100°C)	环境温度过高 通过关闭电源而多次对过负载警报复位后进行了运行	用温度计测量环境温度 通过警报记录的显示 (Fn000) 确认过负载警报	改善伺服单元的安装条件, 降低环境温度。 变更警报的复位方法。
	负载过大, 或运行时超过了再生处理能力	通过累积负载率 Un009 来确认运行中的负载, 通过再生负载率 (Un00A) 来确认再生处理能力	重新探讨负载条件、运行条件。
	伺服单元的安装方向、与其他伺服单元的间隔不合理	确认伺服单元的安装状态	根据伺服单元的安装标准进行安装。
	伺服单元故障	—	可能是伺服单元故障。 更换伺服单元。
A.7AB: 伺服单元内置风扇停止	伺服单元内部的风扇停止转动	确认是否卡入了异物	去除异物后, 仍然发生警报时, 有可能是伺服单元故障。 更换伺服单元。
	第一次接通绝对值编码器的电源 拆下编码器电缆后又进行了连接	确认是否是第一次接通电源 确认是否是第一次接通电源	进行编码器的设定操作 (Fn008)。 确认编码器的连接, 进行编码器的设定操作 (Fn008)
A.810: 编码器备份警报 * 仅在连接绝对值编码器时检出 * 在编码器侧检出	伺服单元的控制电源 (+5V) 以及电池电源均发生故障	确认编码器插头的电池和插头状态是否正确	恢复编码器的供电 (更换电池等) 之后, 进行编码器的设定操作 (Fn008)。
	绝对值编码器故障	—	即使再次进行设定操作也不能解除警报时, 更换伺服电机。
	伺服单元故障	—	可能是伺服单元故障。 更换伺服单元。
A.820: 编码器和数校验警报 * 在编码器侧检出	编码器故障	—	· 绝对值编码器时。 再次设定 (Fn008) 编码器, 仍然频繁发生警报时, 有可能是伺服单元故障。更换伺服电机。 · 旋转型绝对值编码器或增量型编码器时有可能是伺服电机故障。 更换伺服电机。
	伺服单元故障	—	可能是伺服单元故障。 更换伺服单元。
A.830: 编码器电池警报 (绝对值编码器的电池电压在规值以下)	电池连接不良、未连接 电池电压低于规值 (2.7V)	确认电池的连接 测量电池的电压	正确连接电池。 更换电池。
	伺服单元故障	—	可能是伺服单元故障。 更换伺服单元。
A.840: 编码器数据警报 * 在编码器侧检出	编码器误动作	—	再次接通电源, 仍然发生警报时, 有可能是伺服电机故障。 更换伺服电机。
	由于噪音等的干扰而导致编码器误动作	—	正确进行编码器外围的接线。 (分离编码器电缆与伺服电机主回路电缆、接地处理等)。
A.850: 编码器过速 * 在接通控制电源时检出 * 在编码器侧检出	接通控制电源时, 伺服电机以 200min ⁻¹ 以上的速度旋转	通过电机旋转速度监视 (Un000) 来确认接通电源时的电机速度	将伺服电机转速调节到不满 200min ⁻¹ , 然后接通控制电源。 再次接通电源, 仍然发生警报时, 有可能是伺服电机故障。 更换伺服电机。
	编码器故障	—	再次接通电源, 仍然发生警报时, 有可能是伺服单元故障。 更换伺服单元。
	伺服单元故障	—	再次接通电源, 仍然发生警报时, 有可能是伺服单元故障。 更换伺服单元。

警报编号: 警报名称 (警报内容)	原因	确认方法	处理措施
A.860: 编码器过热 * 仅在连接绝对值编码器时检出 * 在编码器侧检出	伺服电机环境温度过高	测量伺服电机的环境温度	将伺服电机的环境温度调节到 40°C 以下。
	伺服电机以超过额定值的负载运行	通过累积负载率 (Un009) 来确认电机负载	将伺服电机的负载调节到额定值以内后再运行。
	编码器故障	—	再次接通电源, 仍然发生警报时, 有可能是伺服电机故障。 更换伺服电机。
A.8A0: 外部编码器故障	伺服单元故障。	—	再次接通电源, 仍然发生警报时, 有可能是伺服单元故障。 更换伺服单元。
	电机运行, 绝对值外部编码器的原点位置设定失败。	设定原点位置前, 通过全闭环反馈脉冲计数器监视器 (Un00E) 确认电机未运行	设定原点位置时使电机不动作。
A.8A1: 外部编码器模块故障	外部编码器故障	—	更换外部编码器。
	串行转换单元故障	—	更换外部编码器。 更换串行转换单元。
A.8A2: 外部编码器传感器故障 (增量型)	外部编码器故障	—	更换外部编码器。
A.8A3: 外部编码器位置故障 (绝对值)	绝对值外部编码器故障	—	有可能是绝对值外部编码器故障。请根据生产厂家的使用说明书采取相应措施。
A.8A5: 外部编码器过速故障	检出来自外部编码器的过速故障	确认外部编码器的最高速度	在外部编码器的最高速度以下使用。
A.8A6: 外部编码器过热故障	检出来自外部编码器的过热故障	—	更换外部编码器。
A.b31: 电流检出故障 1	U 相电流检出回路故障	—	再次接通电源, 仍然发生警报时, 有可能是伺服单元故障。 更换伺服单元。
A.b32: 电流检出故障 2	V 相电流检出回路故障	—	再次接通电源, 仍然发生警报时, 有可能是伺服单元故障。 更换伺服单元。
A.b33: 电流检出故障 3	电流检出回路故障	—	再次接通电源, 仍然发生警报时, 有可能是伺服单元故障。 更换伺服单元。
	伺服电机主回路电缆断线	确认伺服电机主回路电缆是否断线	修理电机电缆。
A.bF0: 系统警报 0	伺服单元故障	—	再次接通电源, 仍然发生警报时, 有可能是伺服单元故障。 更换伺服单元。
A.bF1: 系统警报 1	伺服单元故障	—	再次接通电源, 仍然发生警报时, 有可能是伺服单元故障。 更换伺服单元。
A.bF2: 系统警报 2	伺服单元故障	—	再次接通电源, 仍然发生警报时, 有可能是伺服单元故障。 更换伺服单元。
A.bF3: 系统警报 3	伺服单元故障	—	再次接通电源, 仍然发生警报时, 有可能是伺服单元故障。 更换伺服单元。
A.bF4: 系统警报 4	伺服单元故障	—	再次接通电源, 仍然发生警报时, 有可能是伺服单元故障。 更换伺服单元。
A.C10: 防止失控检出 * 在伺服 ON 时检出	电机接线的 U、V、W 相序错误	确认电机接线	确认电机接线是否有问题。 如果电机接线没有问题, 再次接通电源后仍然发生警报时, 可能是伺服电机的故障。 更换伺服电机。
	编码器故障	—	再次接通电源, 仍然发生警报时, 有可能是伺服单元故障。 更换伺服单元。
A.C80: 编码器清除异常 (旋转圈数上限值设定异常)	编码器故障	—	再次接通电源, 仍然发生警报时, 有可能是伺服电机故障。 更换伺服电机。
	伺服单元故障	—	再次接通电源, 仍然发生警报时, 有可能是伺服单元故障。 更换伺服单元。
A.C90: 编码器通信故障	编码器连用端口的接触不良, 或插头接线错误 编码器电缆断线、短路, 或使用了超过规定阻抗的电缆	确认编码器连接用端口的状态 确认编码器电缆的状态	再次插入编码器插头, 确认编码器的接线。 使用规格要求的编码器电缆。
	温度、湿度、气体引起的腐蚀; 水滴、切削油引起的短路; 振动引起的插头接触不良 因噪音干扰而产生误动作。	—	改善使用环境, 更换电缆。即使这样仍未改善时, 则更换伺服单元。 正确进行编码器外围的接线 (分离编码器电缆与伺服电机主回路电缆、接地处理等)。
A.C91: 编码器通信位置数据加速度异常	伺服单元故障	—	将伺服电机连接到其他伺服单元上后接通控制电源时, 如果不发生警报, 则有可能是伺服单元故障。 更换伺服单元。
	编码器电缆产生磨入、包层损坏, 信号线受到干扰 编码器电缆与大电流线捆在一起或者相距过近 FG 的电位因电机侧设备 (焊机等) 的影响而产生变动	确认编码器电缆和接线端口的状态 确认编码器电缆的设置状态 确认编码器电缆的设置状态	确认编码器电缆的铺设是否有问题。 将编码器电缆铺设在不会遭受浪涌电压的位置。 将机器接地, 阻止向编码器侧 FG 的分流。

警报编号: 警报名称 (警报内容)	原因	确认方法	处理措施
A.C92: 编码器通信定时器异常	编码器的信号线受到干扰	—	实施编码器接线抗干扰对策。
	编码器承受过大的振动冲击	确认使用情况	降低机械的振动。或正确安装伺服电机。
	编码器故障	—	再次接通电源。仍然发生警报时,有可能是伺服电机故障。 更换伺服电机。
A.CA0: 编码器参数异常	伺服单元故障	—	再次接通电源。仍然发生警报时,有可能是伺服单元故障。 更换伺服单元。
	编码器故障	—	再次接通电源。仍然发生警报时,有可能是伺服电机故障。 更换伺服电机。
A.Cb0 编码器回校校验异常	编码器接线错误、接触不良	确认编码器的接线	确认编码器接线是否有问题。
	编码器电缆规格不同,受到噪音干扰	—	将电缆规格改为双绞合线或者双绞合整体屏蔽线,芯线为 0.12mm2 以上,硬铜软铜绞合线。
	编码器电缆的接线距离过长,受到噪音干扰	—	接线距离最长为 50m。
	FG 的电位因电机侧设备(焊机等)的影响而产生变动	确认编码器电缆和接线端口的状态	将机器接地,阻止向编码器侧 FG 的分流。
	编码器承受过大的振动冲击	确认使用情况	降低机械的振动或正确安装伺服电机。
	编码器故障	—	再次接通电源。仍然发生警报时,有可能是伺服电机故障。 更换伺服电机。
	伺服单元故障	—	再次接通电源。仍然发生警报时,有可能是伺服单元故障。 更换伺服单元。
A.CC0: 旋转圈数上限值不一致	DD 电机的旋转圈数上限值 (Pn205) 与编码器的旋转圈数上限值不同	确认 Pn205	正确设定 Pn205 的设定值 (0 ~ 65535)。
	编码器的旋转圈数上限值与伺服单元的旋转圈数上限值不同,或变更了旋转圈数上限值	确认伺服单元 Pn205 的值	在发生警报时进行设定变更 Fn013。
	伺服单元故障	—	再次接通电源。仍然发生警报时,有可能是伺服单元故障。 更换伺服单元。
A.CF1: 反馈选购模块通信故障 (接收失败)	串行转换单元—伺服单元间的电缆接线错误或接触不良	确认外部编码器的接线	正确进行串行转换单元—伺服单元间的电缆的接线。
	串行转换单元—伺服单元间未使用指定的电缆	确认外部编码器的电缆规格	使用指定的正确电缆。
	串行转换单元—伺服单元间的电缆过长	更换串行转换单元连接电缆的长度	使串行转换单元—伺服单元间的电缆长度在 20m 以内。
A.d00: 位置偏差过大 (在伺服 OFF 的状态下,位置偏差超过了位置偏差过大警报值 (Pn520))	串行转换单元—伺服单元间的电缆包层破损	确认串行转换单元连接电缆	更换串行转换单元—伺服单元间的电缆。
	伺服电机的 U、V、W 的接线不正确	确认伺服电机主回路电缆的接线	确认电机电缆或编码器电缆有无接触不良等问题。
	位置指令的频率较高	试着降低指令脉冲频率后再运行	降低位置指令脉冲频率或指令加速度,或调整电子齿轮比。
A.d01: 伺服 ON 时位置偏差过大警报	位置指令加速度过大	试着降低指令加速度后再运行	加入位置指令加速度时间常数 (Pn216/Pn217) 等的平滑功能。
	相对于运行条件,位置偏差过大警报值 (Pn520) 较低	确认位置偏差过大警报值 (Pn520) 是否适当	正确设定参数 Pn520 的值。
A.d02: 伺服 ON 时速度限制引起的位置偏差过大警报	伺服单元故障	—	再次接通电源。仍然发生警报时,有可能是伺服单元故障。 更换伺服单元。
	伺服 ON 中,位置偏差在 Pn526 的设定值以上的状态时,伺服 ON	确认伺服 ON 时的位置偏差量 (Un008)	进行设定,使在伺服 ON 时清除位置偏差或设定伺服 ON 时正确的位置偏差过大警报值 (Pn526)。
A.d10: 电机 - 负载位置间偏差过大	在位置偏差积累状态下使伺服 ON,则通过伺服 ON 时速度限制值 (Pn529) 来限制速度。在该状态下输入位置指令,超出了位置偏差过大警报值 (Pn520) 的设定值。	—	进行设定,使在伺服 OFF 时清除位置偏差或设定正确的位置偏差过大警报值 (Pn520) 或将伺服 ON 时速度限制值 (Pn529) 设定为正确的值。
	电机旋转方向与外部编码器安装方向相反	确认电机旋转方向与外部编码器安装方向	将外部编码器安装方向反过来,或将“外部编码器的使用方法 (Pn002.3)”的旋转方向设定为相反方向。
A.E71: 安全选购模块 检出失败警报	工件台等的负载位置和外部编码器接合部的安装故障	确认外部编码器接合部	再次进行机械性结合。
	伺服单元与安全选购模块连接不良	确认伺服单元与安全选购模块的连接	正确连接安全选购模块。
	拆下了安全选购模块	-	通过数字操作器或 SigmaWin+ 执行 Fn014 (清除选购模块检出结果),然后再次接通电源。
	安全选购模块的故障 伺服单元故障	-	更换安全选购模块。 更换伺服单元。
A.E72: 反馈选购模块 检出失败警报	伺服单元与反馈选购模块连接不良	确认伺服单元与反馈选购模块的连接	正确连接反馈选购模块。
	拆下了反馈选购模块	—	执行 Fn014 (清除选购模块检出结果),然后再次接通电源。
	反馈选购模块的故障 伺服单元故障	—	更换反馈选购模块。 更换伺服单元。

警报编号: 警报名称 (警报内容)	原因	确认方法	处理措施
A.E74: 安全选购模块不支持警报	安全选购模块的故障	—	更换安全选购模块。
	连接了不支持的安全选购模块	参照所连接的伺服单元与安全选购模块的产品目录	连接支持的安全选购模块。
A.E75: 反馈选购模块不支持警报	反馈选购模块的故障	—	更换反馈选购模块。
	连接了不支持的反馈选购模块	参照所连接的反馈选购模块的产品目录或伺服单元手册	连接支持的反馈选购模块。
A.Eb1: 安全功能用信号输入时间异常	硬接线基极封锁功能的输入信号 / HWBB1、/HWBB2 启动的时间差在 10 秒钟以上	测量 2 个输入信号的时间差	可能是 /HWBB1、/HWBB2 的输出信号回路、机器故障、伺服单元输入信号回路故障、输入信号用电缆断线。确认故障或断线。
	三相电源接线不良	确认电源接线	确认电源接线是否有问题。
A.F10: 电源线路缺相 (在主电源 ON 的状态下, R、S、T 相中某一相的低电压状态持续了 1 秒钟以上) 在接通主回路电源时检出	三相电源不平衡	测量三相电源各相的电压	修正电源的不平衡 (调换相位)。
	没有进行单相输入的参数设定 (Pn00B2 = 1) 就直接输入了单相电源	确认电源和参数设定	正确设定电源输入和参数。
A.F26	伺服单元故障	—	再次接通电源。仍然发生警报时,有可能是伺服单元故障。 更换伺服单元。
A.F28	转矩指令达到最大值	—	正确接好电机的 UVW 动力线
FL-1*2: 系统警报	位置指令异常	查看 6064 与 607A 的值	正确输入位置指令
FL-2*2: 系统警报	伺服单元故障	—	再次接通电源。仍然发生警报时,有可能是伺服单元故障。 更换伺服单元。
FL-2*2: 系统警报	伺服单元故障	—	再次接通电源。仍然发生警报时,有可能是伺服单元故障。 更换伺服单元。

警告原因及处理措施

警告编号: 警告名称 (警告内容)	原因	确认方法	处理措施
A.900: 位置偏差过大	伺服电机的 U、V、W 的接线不正确	确认伺服电机主回路电缆的接线	确认电机电缆或编码器电缆有无接触不良等问题。
	伺服单元的增益较低	确认伺服单元的增益是否过低	通过高级自动调谐等提高伺服增益。
	位置指令脉冲的频率较低	试着降低指令脉冲频率后再运行	降低位置指令脉冲频率或指令加速度,或调整电子齿轮比。
A.901: 伺服 ON 时位置偏差过大	位置指令加速度过大。	试着降低指令加速度后再运行	加入位置指令加速度时间常数 (Pn216/Pn217) 的平滑功能。
	相对于运行条件,位置偏差过大警报值 (Pn520) 较低	确认位置偏差过大警报值 (Pn520) 是否适当	正确设定 Pn520 的值。
	伺服单元故障	—	再次接通电源。仍然发生警报时,有可能是伺服单元故障。 更换伺服单元。
A.910: 过载 (变为过载警报 (A.710 A.720) 之前的警告)	超过 $\frac{Pn520 \times Pn51E}{100}$ 设定的比例	—	进行设定,使在伺服 OFF 时清除位置偏差或设定伺服 ON 时适当的位置偏差过大警告值 (Pn526)。
	电机接线、编码器接线不良或连接不良	确认接线	确认电机接线、编码器接线是否有问题。
A.911: 振动	电机运行超过了过载保护特性	确认电机的过载特性和运行指令	重新探讨负载条件、运行条件。或者重新研讨电机容量。
	由于机械性因素而导致电机不驱动,造成运行时的过载过大	确认运行指令和电机速度	改善机械性因素。
A.920: 再生过载 (变为再生过载 (A.320) 之前的警告)	伺服单元故障	—	可能是伺服单元故障。更换伺服单元。
	检出电机动作中的异常振动	确认电机的异常声音和运行时的速度、转矩波形	降低电机速度或通过单参数调谐等降低伺服增益。
A.921: DB 过载 (变为 DB 过载 (A.731) 之前的警告)	转动惯量比 (Pn103) 的值比实际值大或进行了大的变动	确认转动惯量比	正确地设定转动惯量比 (Pn103)。
	电源电压超过规格范围。	测量电源电压。	将电源电压设定在规格范围内。
A.922: DB 停止时的旋转能量超过 DB 电阻的容量	外置再生电阻值、伺服单元的容量或再生电阻容量不足,或处于连续再生状态	再次确认运行条件或容量 (容量选择软件 HCServoWorks 等)	变更再生电阻值、再生电阻容量或伺服单元容量。再次进行运行条件的调整 (容量选择软件 HCServoWorks 等)。
	连续承受负载,处于连续再生状态	确认向运行中的伺服电机施加的负载	再次探讨包括伺服、机械、运行条件在内的系统。
A.923: DB 停止时的旋转能量超过 DB 电阻的容量	电机在被外力驱动	确认运行状态	不要通过外力驱动电机。
	伺服单元故障	—	尝试以下措施 · 降低伺服电机的指令速度。 · 减小转动惯量。 · 减少 DB 停止的次数。
A.924: DB 停止时的旋转能量超过 DB 电阻的容量	伺服单元故障	—	可能是伺服单元故障。 更换伺服单元。

警告编号: 警告名称 (警告内容)	原因	确认方法	处理措施
A.930: 绝对值编码器的电池故障 (绝对值编码器电池的 电压低于规定值) * 仅连接绝对值编码器时 检出	电池连接不良、未连接	确认电池的连接	正确连接电池。
	电池电压低于 规定值 (2.7V)	测量电池的电压	更换电池。
	伺服单元故障	—	可能是伺服单元故障。 更换伺服单元。
A.941: 变更了需要重新接通电 源的参数	变更了需要重新接通电源的参数	—	再次接通电源。
A.971: 欠电压	200V 用伺服单元、AC 电源电压在 140V 以下, 400V 用伺服单元、AC 电源电压 在 280V 以下	测量电源电压	将电源电压调节到正常范围。
	运行中电源电压下降	测量电源电压	增大电源容量。
	发生瞬时停电	测量电源电压	如果变更了瞬时停电保持时间 (Pn509), 则设定为较 小的值。
	伺服单元的保险丝熔断	—	更换伺服单元, 连接电抗器后再使用伺服单元。
A.971: 欠电压	伺服单元故障	—	可能是伺服单元故障。 更换伺服单元。
	伺服单元 ON 中检出了超程	使用输入信号监视 (Un005) 确认超程信号的状 态	可以从伺服电机的动作、状态来判断的故障原因及处 理措施”。 另外, 如果无法用输入信号监视 (Un005) 确认超程 信号, 则可能是检出了瞬间超程。采取以下措施 · 不从上位装置向超程范围发送指令。 · 确认超程信号的信号接线。 · 采取抗干扰对策。
A.9B0	软限位设置错误	查看 607D 的值是否设置正确	在正确范围内设置 607D 的值
A.9B1	原点偏移设置错误	查看 607D、607C 的值是否设置正确	在正确范围内设置 607D、607C 的值
A.9B2	同步帧数据丢失	查看是否使用带屏蔽功能的双绞屏蔽通信线; 查 看驱动器是否良好接地;	1. 请使用带屏蔽功能的双绞屏蔽线缆; 2. 请按标准接线指导接线; 3. 设置预使用的同步周期后, 将驱动器 EtherCAT 通信状态机切换至运行模式; 4. 若主站同步周期本身误差较大, 请调整主站或增大 从站的同步丢失故障容限 Pn785
A.9B3	EtherCAT 通讯中断	查看是否使用带屏蔽功能的双绞屏蔽通信线; 查 看驱动器是否良好接地;	1. 请使用带屏蔽功能的双绞屏蔽线缆; 2. 请按标准接线指导接线; 3. 设置预使用的同步周期后, 将驱动器 EtherCAT 通信状态机切换至运行模式; 4. 若主站同步周期本身误差较大, 请调整主站或增大 从站的同步丢失故障容限 Pn785
A.9B4	EtherCAT 网络初始化失败	未烧录设备配置文件, 伺服驱动器故障	烧录对应的 xml 文件, 更换伺服驱动器
A.9B5	电流环状态报警	转矩指令小于百分 30, 且电机不动	正确设置转矩指令以及最大转矩限制
A.9B7	使能条件不满足	在硬件基极未封锁状态下, 有条件未满足, 无法使 能; 母线电压欠压	确认母线电压供电是否正常; 确认 CN3 端口
A.9B8	任意一路安全接口输入未接 +24V	查看安全功能使用信号 STO(CN3) 是否接入	确认安全的前提下, 恢复安全接口
A.9B9	紧急停止警告	检查 Pn515.3 E-Stop 信号分配, 其对应 DI 端子 逻辑是否被置为有效。	检查运行模式, 确认安全的前提下, 解除 DI 刹车有效 信号

功能码定义

数字输入端子 (DI) 功能定义说明 ww		
功能名称	功能说明	功能使用
P-OT	正向超程	当机械运动超过可移动范围限位开关动作, 进入超程保护功能 有效: 正向超程, 禁止正向驱动 无效: 正常范围, 允许正向驱动
N-OT	负向超程	当机械运动超过可移动范围限位开关动作, 进入超程保护功能 有效: 负向超程, 禁止负向驱动 无效: 负常范围, 允许负向驱动
/HomeSwitch	回原信号	无效: 回原未完成 有效: 回原完成
EXT	探针信号	无效: 不使用探针进行位置锁存 有效: 使用探针进行位置锁存
BK	抱闸信号	无效: 制动器动作 有效: 制动器不动作

ManualNo.	HPPD1420000
Version	1.1
Date	August,2023

Hardware Instruction for Y7S-series Advanced Servo Drive (EtherCAT)

1 Preface

Thank you for purchasing Y7-series servo drive. This manual mainly describes the safety use, installation and wiring for Y7-series EtherCAT servo drive. For more details, please refer to < User Manual for Y7 Series EtherCAT Servo Drive >.



Confirm the following items when unpacking:

Item	Name	Quantity
1	Y7S-series advanced servo drive	1
2	Accessories	
	STO terminal	1
	50pin terminal (CN1)	1
3	Hardware Instruction for Y7S-series Advanced Servo Drive (EtherCAT)	1
4	Qualified certificate	1

- Power supply input terminal *1 and power output terminal *1 for 3kw and below models.
- General N models do not have STO terminal and 50pin terminal (CN1 interface).
- Fully functional Model F includes second encoder terminal (CN4 interface).
- Check if there are some damages to the products during transportation.
- Any questions, please contact the HCFA Technology.

Safety precautions

Safety symbols

Please pay attention to the following safety precautions anywhere and anytime during acceptance inspection, installation, wiring, operation and maintenance. In this manual, the safety precautions are ranked as "DANGER" and "CAUTION".

	Indicates that incorrect handling may result in death or severe injury.
--	---

	Indicates that incorrect handling may result in medium or slight personal injury or physical damage.
--	--

The following graphic symbols shall be used to describe the matters to be observed

	Indicates "Prohibitions"(Indicates what must not be done).
	Indicates "Strict Enforcement"(Indicates what must be done.)

⚠ DANGER		
About Installing and wiring		
	Do not connect the motor to the commercial power.	To prevent fire or malfunction.
	Do not place the combustibles around the servo motor and drive.	To prevent fire.
	Be sure to protect the drives through the case, and leave specified clearances between the case or other equipment and the drive.	To prevent electric shock, fire or malfunction.
	Install it at the place free from excessive dust and dirt, water and oil mist.	To prevent electric shock, fire, malfunction or damage.
	Install the equipment to incombustibles, such as metal.	To prevent fire.
	Any person who is involved in wiring and inspection should be fully competent to do the work.	To prevent electric shock.
	FG terminal of motor and drive must be grounded.	To prevent electric shock.
	Perform the wiring correctly after cut off the breaker.	To prevent electric shock, injury, malfunction or damage.
	Have the insulation processing when connecting cables.	To prevent electric shock, fire or malfunction.

About operation and running		
	During operation, never touch the internal parts of the drive.	To prevent burns or electric shock.
	The cables should not be damaged, stressed loaded, or pinched.	To prevent electric shock, malfunction or damage.
	During operation, never touch the rotating parts of the servo motor.	To prevent injury.
	Do not immerse the cable in oil or water when operation	To prevent fire.
	Operate the switches and wiring with dry hand.	To prevent electric shock, injury or fire.
	Do not touch the keypad directly when using the motor with shaft-end keypad	To prevent injury.
	Do not touch the surface of motor, drive and radiator.	To prevent burns or parts damaged.
	Do not drive the motor by external drive.	To prevent fire.
About other safety instructions		
	Confirm the equipment's safety after the earthquake happens.	To prevent electric shock, injury or fire.
	Installing and setting correctly to prevent fire and personal injury when earthquake happens.	To prevent injury, electric shock, fire, malfunction or damage.
	Provide an external emergency stop circuit to ensure that operation can be stopped and power switched off immediately.	To prevent injury, electric shock, fire, malfunction or damage.
About maintenance and inspection		
	Before wiring or inspection, turn off the power and wait for 5 minutes or more. And it's not allowed to disassemble the servo drive.	To prevent electric shock.

⚠ CAUTION		
About installing and wiring		
	Please follow the specified combination of the motor and drive.	To prevent fire or malfunction.
	Do not touch the terminals of connector directly.	To prevent electric shock or malfunction.
	Do not block intake and prevent the foreign matters from entering into the drive.	To prevent electric shock or fire.
	Fix the motor and have the test run away from the mechanical system. After confirming the operation, the motor can be securely mounted to mechanical system.	To prevent injury.
	The servo motor must be installed in the specified direction.	To prevent injury or malfunction.
	Install the equipment correctly in accordance with its weight and rated output.	To prevent injury or malfunction.
About operation and running		
	Do not stand on servo equipment. Do not put heavy objects on equipment.	To prevent electric shock, injury, fault or damage.
	The parameter settings must not be changed excessively otherwise, the operation of the servo will be unstable.	To prevent injury.
	Keep it away from the direct sunlight.	To prevent malfunction.
	Do not subject the motor and motor shaft to strong impacts.	To prevent malfunction.
	The electromagnetic brake on the servo motor is designed to hold the servo motor shaft and should not be used for ordinary braking.	To prevent injury or malfunction.
	When power is restored after an instantaneous power failure, keep away from the machine because the machine may be restarted suddenly (design the machine so that it is secured against hazard if restarted).	To prevent injury.
	Do not install or operate a faulty servo motor or drive.	To prevent injury, electric shock or fire.
	Check the power specification.	To prevent fault.
	The electromagnetic brake may not hold the servo motor shaft. To ensure safety, install a stopper on the machine side.	To prevent injury.
	A sudden restart is made if an alarm is reset with the run signal on.	To prevent injury.
	Connect the relay for emergency stop and for brake in series.	To prevent injury or malfunction.
About transportation and storage		
	Do not subject the equipment to the place with rain, waterdrop, poisonous gases or liquids.	To prevent malfunction.
	Do not carry the servo motor by the cables, shaft or encoder during transportation.	To prevent injury or malfunction.

	Do not drop or dump the motor during transportation and installation.	To prevent injury or malfunction.
	When long-term storage is required, please consult HCFA Technology.	To prevent malfunction.
	Store the unit in a place in accordance with the instruction manual.	To prevent malfunction.
About other safety instructions		
	Please dispose the battery according to your local laws and regulations.	
	When disposing of the product, handle it as industrial waste.	
About maintenance and inspection		
	Do not disassemble and/or repair the equipment on customer side.	To prevent malfunction.
	Do not turn on or switch off the main power frequently.	To prevent malfunction.
	When the drive become faulty, switch off the control circuit and main power.	To prevent fire.
	If the servo motor is to be stored for a long time, switch off the power.	To prevent misoperation and injury.
About maintenance and inspection		
< Warranty period > The term of warranty for the product is 18 months from the date of manufacture. It's exceptional to brake motors as they are warranted when acceleration / deceleration times is not beyond the specified service life.		
< Warranty coverage > This warranty applies only when the condition, method, environment, etc. of use are in compliance with the terms and conditions and instructions that are stated in the instruction manual and user manual for the Product. However, even during warranty period, the repair cost will be charged on customer in the following cases. 1) A failure caused by improper storing or handling, repair and modification. 2) A failure caused by the parts which have dropped down or damaged after acceptance. 3) A failure caused when the products have been used beyond the product specification. 4) A failure caused by external factors such as inevitable accidents, including but not limited to fire, earthquake, lightning stroke, windstorm disaster, flood, salt damage, abnormal fluctuation of voltage and other natural disaster. 5) A failure caused by the intrusion of water, oil, metal and other foreign matters. The warranty coverage is only for the product itself. We assume no responsibilities for any losses of opportunity and/or profit incurred by customer due to a failure of the product.		

2 Product introduction and model selection

Introduction for servo drive nameplate

Description of side labels of Y7Smart series servo drives.

Model name: MODEL: HN-Y7EB040A-S

Power specification: INPUT: 1PH/3PH 200-240V 50/60HZ, OUTPUT: 3PH 0-240V 2.8A 400W

Serial number: S/N: Y2322175901, P/N: 100022Y2393000000000

CE logo, MADE IN CHINA, and QR code are also present.

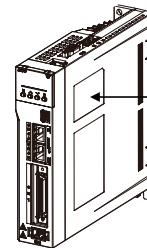

Nameplate

Model name identification

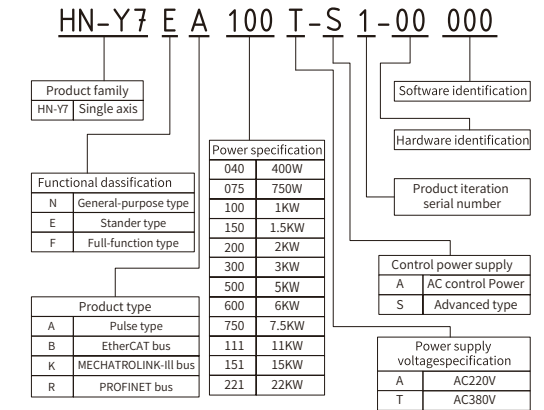

3 Product specification

Environmental specifications

Items	Specifications
Environmental requirements	Open environment or indoor use
Environmental temperature	0°C ~ 50°C (Environmental Temperature above 45°C, Derate 10% for every 5 degree increase) / -20°C ~ + 70°C
Storage temperature	-20°C ~ 65°C (Maximum temperature guarantee: 80°C 72h No condensation)
Ambient humidity	20% ~ 85%RH or less (No condensation)
Storage humidity	20% ~ 85%RH or less (No condensation)
Vibration resistance	5.88m/s ² (0.6G) or less, 10-60Hz (Do not connect at the resonance point)
Impact strength	Acceleration 100m/s ² or less(XYZ)
Protection level	IP20
Cleanliness	• Free from corrosive gas, flammable gas • Free from water, oil, chemical splash
Altitude	1000m or less (It can be used after derating at 1000 to 2000m)
Pollution level	2
Overvoltage classification	III
Short-circuit current	5Ka
Others	No electrostatic interference, strong electric field, strong magnetic field, radiation, etc.

Basic specifications for models of 220VAC

Items	Specifications					
	040	075	100	150	200	
Models HN-Y7 □ □ □ □ A-S** ****						
Maximum applicable motor capacity (kW)	0.4	0.75	1.0	1.5	2.0	
Continuous output current (Arms)	2.8	5.5	7.6	11.6	15.6	
Instantaneous max. output current (Arms)	9.3	16.9	17	28	39	
Main circuit	Power voltage (Arms)	Sing-phase AC200 ~ 240V, 50/60Hz		3-phase 200 ~ 240VAC, 50/60Hz		
	Current (Arms)	2.5	4.1	5.7	7.3	10
Regenerative resistor	Share the main circuit power supply					
	Built-in resistor	Resistance (Ω)	—	50	50	20
	Capacity (W)	—	80	80	100	100
External mini. allowable resistance (Ω)	40	40	35	20	20	
Overvoltage level	III					

Basic specifications for models of 380V AC

Items	Specifications																			
Models HN-Y7 □□ ***T-S** ****	100	150	200	300	500	600	750	111	151	221										
Maximum applicable motor capacity (kW)	1	1.5	2.0	3.0	5.0	6.0	7.5	11	15	22										
Continuous output current (Arms)	4.7	5.4	8.4	11.9	16.5	20.8	25.7	28.1	37.2	52										
Instantaneous max. output current(Arms)	16.9	17	24	31	44	52	65	70	88	105										
Main circuit	3-phase 330 ~ 440VAC, 50/60Hz																			
Power voltage (Arms)																				
Current (Arms)	2.9	4.3	5.8	8.6	14.5	17.4	21.7	23.4	29.6	43.4										
Control power	Share the main circuit power supply 3-phase 330 ~ 440VAC, 50/60Hz																			
Regenerative resistor	Built-in resistor	Resistance (Ω)									50	50	50	40	25	20	20	—	—	—
	Capacity (W)	Capacity (W)									80	80	80	100	100	100	—	—	—	—
	External mini. allowable resistance (Ω)	Resistance (Ω)									40	40	40	35	25	20	20	15	10	10
Overvoltage level	III																			

Note 1) When using an external regenerative resistor at a normal rated load factor, be sure to lower the rating before using the resistor when the temperature of the resistor reaches 200°C to 300°C. For the load characteristics of the resistor, please consult HCFA Technology.

Note 2) For safety, it is recommended to use an external regenerative resistor with a temperature switch.

4 Installation and size of servo drive

Y7Smart series drive configuration table

Servo drive (AC220V)	SIZE A			SIZE B			SIZE D		
	HN-Y7 □□ 040A-S	HN-Y7 □□ 075A-S	HN-Y7 □□ 100A-S	HN-Y7 □□ 150A-S	HN-Y7 □□ 200A-S	HN-Y7 □□ 300A-S	HN-Y7 □□ 400A-S	HN-Y7 □□ 500A-S	HN-Y7 □□ 600A-S
Servo drive (AC380V)	SIZE C	SIZE D	SIZE E	SIZE F	SIZE G				
	HN-Y7 □□ 100T-S	HN-Y7 □□ 200T-S	HN-Y7 □□ 300T-S	HN-Y7 □□ 500T-S	HN-Y7 □□ 600T-S	HN-Y7 □□ 111T-S	HN-Y7 □□ 151T-S	HN-Y7 □□ 221T-S	HN-Y7 □□ 221T-S

Y7Smart series drive mounting dimension

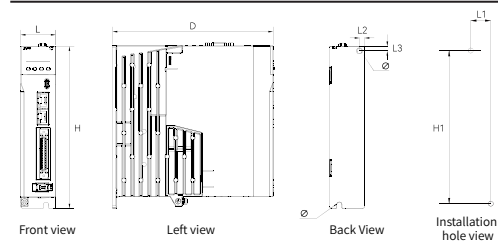

Structure	SIZE A	SIZE B	SIZE C	SIZE D (AC220V)	SIZE D (AC380V)	SIZE E	SIZE F	SIZE G
L(mm)	37.0	47.0	55.0	70.0	90.0	90.0	90.0	194.0
H(mm)	172.0	172.0	172.0	172.0	182.8	243.3	260.0	
D(mm)	170.0	170.0	180.0	180.0	192.5	205.2	205.0	
L1(mm)	21.3	31.3	39.7	54.7	76.0	76.0		
L2(mm)	5.5	5.5	5.5	5.5	7.0	7.0		
L3(mm)	5.0	4.5	5.0	5.0	6.0	6.0		
H1(mm)	162.8	162.8	163.0	163.0	168.0	227.5		
Aperture(φ)	5.5	5.5	5.5	5.5	6.0	6.0		
Screw hole	2-M5	2-M5	2-M5	2-M5	3-M5	4-M5		
Locking torque (Nm)	3.5N-M	3.5N-M	3.5N-M	3.5N-M	3.5N-M	3.5N-M		
Weight (kg)	0.76	1.01	1.21	1.45	1.5	2.2	3.6	8.77

Cabinet installation instructions

Attention

- During installing servo drive, please do not seal the suction vent, and do not dumping place the servo, otherwise it will cause malfunction.
- In order to make the cooling fan can have low windage, to effectively discharge quantity of heat, please follow the installation distance recommended value when install one or more servos.
- Please avoid arrange servos up and down, because of the heat from the bottom operational drive, easy to cause under drive unnecessary temperature increase.

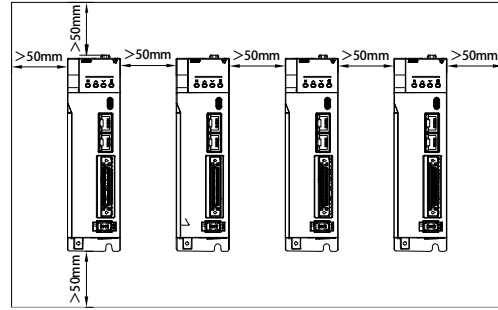

Note1) The installation interval of the servo driver in the figure is 50mm according to the condition of no external ventilation at the highest 55°C. Depending on the customer's heat dissipation strip, such as cabinet temperature, ventilation conditions, etc., if the ambient temperature of the servo driver can be guaranteed to be lower than 55°C, the interval distance can be less than 50 mm.

Structure installation instructions

Attention

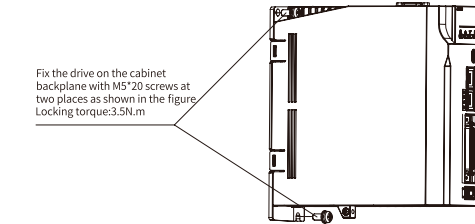

High power drive installation instructions

This description applies to HN-Y7 □□ 111T-S, HN-Y7 □□ 151T-S, and HN-Y7 □□ 221T-S models. Users can choose wall-mounted installation or through-wall installation based on device requirements.

Wall-mounted installation:

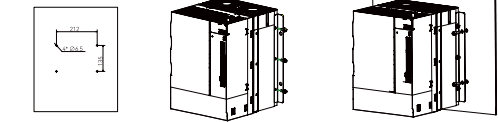

- Use tools to open four φ4.5 holes on the back plate of the electric cabinet, and the specific dimensions are as shown in the figure.
- Take out the mounting bracket and six M5 * 12 screws in the packaging bag in the box, and fix the mounting bracket on both sides of the drive with screws, as shown in the figure.
- Fix the drive on the back plate of the cabinet with M6 socket head cap screws and ensure it is firm and reliable. The recommended locking torque is 3N · m.

Through-wall installation:

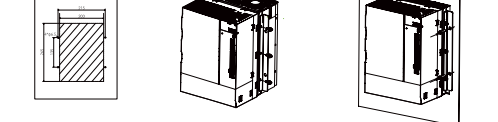

- Use tools to open four φ4.5 holes on the back plate of the electric cabinet, and the specific dimensions are as shown in the figure.
- Take out the mounting bracket and six M5 * 12 screws in the packaging bag in the box, and fix the mounting bracket on both sides of the drive with screws, as shown in the figure.
- Fix the drive on the back plate of the cabinet with M6 socket head cap screws and ensure it is firm and reliable. The recommended locking torque is 3N · m.

5 Wiring

Recommended cables

Terminals	Name	Models HN-Y7 □□□□ A-S					
		040	075	100	150	200	
LC1、LC2	Control power input terminal	—					
L1、L2、L3	Main circuit power input terminal	0.82mm ² (AWG18)			1.318mm ² (AWG16)		2.075mm ² (AWG14)
U、V、W	Terminal for servo motor	0.82mm ² (AWG18)	1.318mm ² (AWG16)		2.627mm ² (AWG13)	4.17mm ² (AWG11)	
B1、B2	Terminal for external regenerative resistor	Determined according to the actual power of the external resistor, you can consult the resistor manufacturer or our technicians					
	Ground terminal	> 2.075mm ² (<AWG14)					

Terminals	Name	Models HN-Y7 □□□□ T-S									
		100	150	200	300	500	600	750	111	151	221
LC1、LC2	Control power input terminal	—									
L1、L2、L3	Main circuit power input terminal	0.82mm ² (AWG18)	1.646mm ² (AWG15)			3.332mm ² (AWG12)	4.17mm ² (AWG11)	5.26mm ² (AWG10)	6.63mm ² (AWG9)	8.37mm ² (AWG8)	10.55mm ² (AWG7)
U、V、W	Terminal for servo motor	1.026mm ² (AWG17)	1.646mm ² (AWG15)	2.627mm ² (AWG13)	3.332mm ² (AWG12)	4.17mm ² (AWG11)	6.63mm ² (AWG9)	8.37mm ² (AWG8)	10.55mm ² (AWG7)	13.3mm ² (AWG6)	
B1、B2	Terminal for external regenerative resistor	Determined according to the actual power of the external resistor, you can consult the resistor manufacturer or our technicians									
	Ground terminal	> 2.075mm ² (<AWG14)									

Note 1) If used in a closed pipe, wire groove, etc., or the ambient temperature higher than 55°C, please increase the size of the wires.

Connector type terminal driver port definition and wiring description

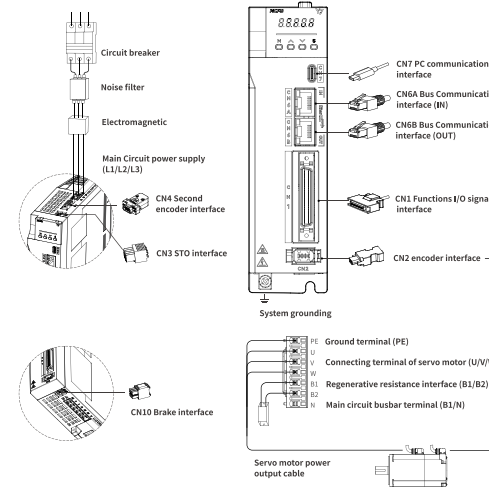

Fence type terminal driver port definition and wiring description

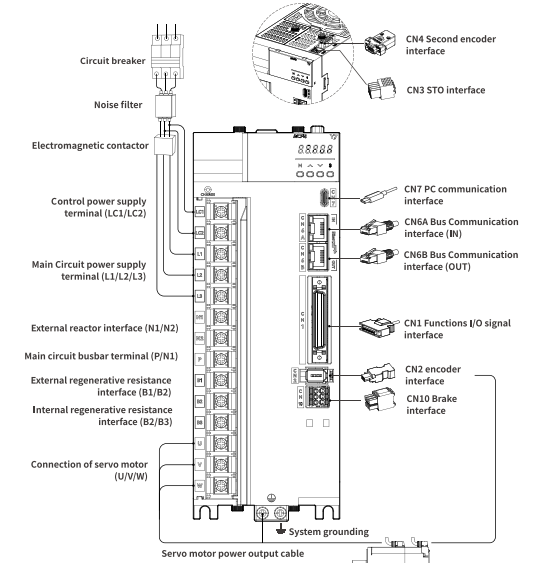

CN1 Terminal arrangement

2	SG	GND	1	SG	GND	26	OUT3-	Assignable Output signal	27	OUT4+	High speed output
4	SEN	SEN signal input	3	PL1	Open collector instruction with internal power supply 12V	28	OUT4-	High speed output	29	OUT1+	Assignable Output signal
6	SG	GND	5	V-REF	Analog speed input instruction	30	OUT1-	Assignable Output signal	31	ALM+	Alarm Signal Output
8	N/A	N/A	7	N/A	N/A	32	ALM-	Alarm Signal Output	33	PAO	The number of encoder frequency division pulse output - A phase
10	SG	GND	9	T-REF	Analog torque input instruction	34	/PAO	The number of encoder frequency division pulse output - A phase	35	PBO	The number of encoder frequency division pulse output - B phase
12	N/A	N/A	11	N/A	N/A	36	/PBO	The number of encoder frequency division pulse output - B phase	37	OUT5+	High speed output
14	CLR	collector Clear input	13	PL2	Open collector instruction with internal power supply 12V	38	OUT5-	High speed output	39	DAC0	Analog output 1
16	N/A	N/A	15	N/A	N/A	40	SI0	Homing signal input	41	SI1	Probe 1
18	PL3	Open collector instruction with internal power supply 12V	17	N/A	N/A	42	SI2	Forward Drive Prohibit	43	SI3	Reverse Drive Prohibit
20	/PCO	The number of Encoder frequency pulse	19	PCO+	The number of encoder frequency division pulse output - C phase	44	SI4	Probe 2	45	N/A	N/A
22	N/A	N/A	21	N/A	N/A	46	N/A	N/A	47	DI (COM)	External 24V power input
24	N/A	N/A	23	N/A	N/A	48	DAC1	Analog output 2	49	OCZ	Z signal Open collector instruction output
			25	OUT3+	Assignable Output signal	50	TH	External temperature detection			

Note 1) Only full-function type F supports high-speed output, analog input and pulse frequency division output.
 Note 2) General N type without CN1.

Encoder signal (CN2)

Interface layout	Pin1	Pin2	Pin3	Pin4	Pin5	Pin6	Shell
	Encoder power supply +5V	Encoder power supply 0V	-	-	Serial data (+)	Serial data (-)	-

STO signal (CN3)

Driver STO interface	STO safety connector	Interface layout					
		EDM+ 8 7 EDM- HWBB2+ 6 5 HWBB2- HWBB1+ 4 3 HWBB1- NC- 2 1 NC+					
Pin1	Pin2	Pin3	Pin4	Pin5	Pin6	Pin7	Pin8
NC+	NC-	HWBB1-	HWBB1+	HWBB2-	HWBB2+	EDM-	EDM+
-	-	Input 1-	Input 1+	Input 2-	Input 2+	Output-	Output +

Secondary encoder signal (CN4)

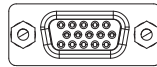

Pin	Incremental ABZ encoder with differential Hall sensor	Sin and cos encoder with differential Hall sensor and Z signal	BISS encoder	TAMAGAWA encoder
1	+5V output current output ≤ 300mA	+5V output current output ≤ 300mA	+5V output current output ≤ 300mA	+5V output current output ≤ 300mA
2	0V output	0V output	0V output	0V output
3	Hall U+	Hall U+	-	-
4	Hall U-	Hall U-	-	-
5	Hall V+	Hall V+	-	-
6	Increment encoder A-	Sin encoder Sin -	BISS-C CLK-	Serial DATA-
7	Increment encoder B-	Sin encoder Cos -	BISS-C DATA-	-
8	Increment encoder Z-	Increment encoder Z-	-	-
9	Hall W+	Hall W+	-	-
10	Hall V-	Hall V-	-	-
11	Increment encoder A+	Sin encoder Sin +	BISS-C CLK+	Serial DATA+
12	Increment encoder B+	Sin encoder Cos +	BISS-C DATA+	-
13	Increment encoder Z+	Increment encoder Z+	-	-
14	Hall W-	Hall W-	-	-
15	Temperature sensor signal	Temperature sensor signal	Temperature sensor signal	Temperature sensor signal
Shell	Shield	Shield	Shield	Shield

Communication interface (CN6)

Interface layout	Pin1	Pin2	Pin3	Pin4	Pin5	Pin6	Pin7	Pin8
	TD+	TD-	RD+	-	-	RD-	-	-

Brake interface (CN10)

Driver brake interface	STO connector	Interface layout			
		T- 6 5 T+ BK- 4 3 BK+ 0V 2 1 24V			
Pin1	Pin2	Pin3	Pin4	Pin5	Pin6
24V	0V	BK+	BK-	T+	T-
24V power supply		Servo brake wire		Temperature control+	Temperature control-

Note 1) : The brake DC24V power supply is not to be shared with the CN1 control circuit power supply. The NTC specification is KTY84.

Connection example of input and output signals (bus type)

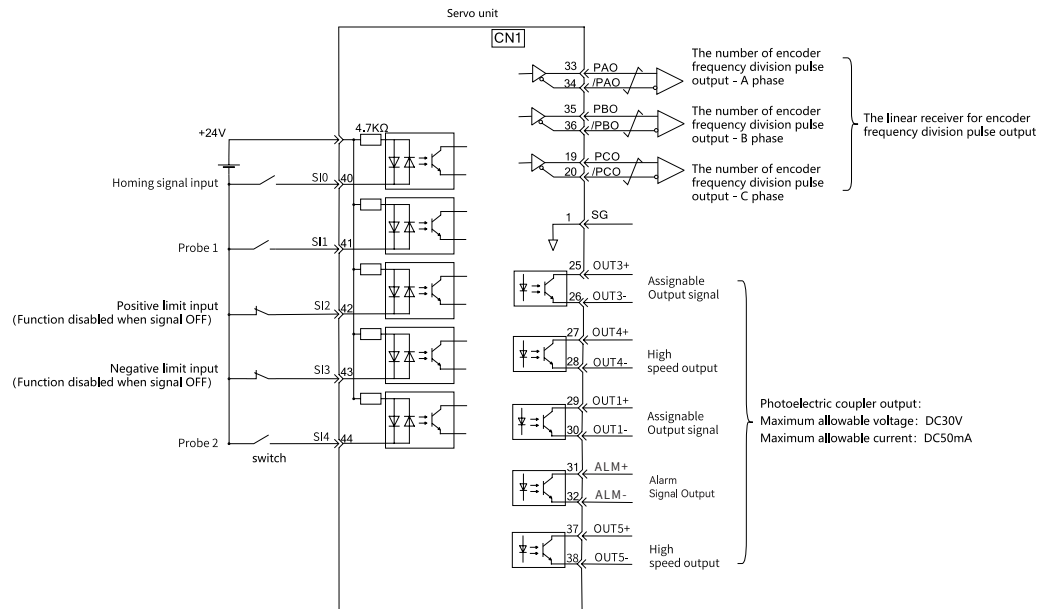

Brake wiring

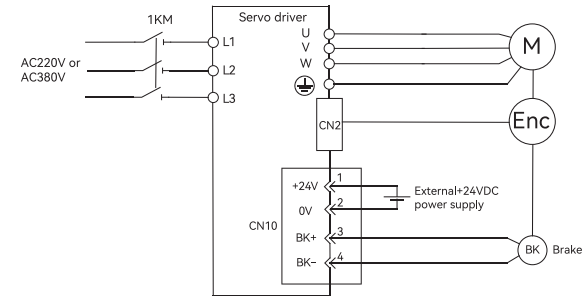

1QF: Wiring circuit breaker
 FIL: Noise filter
 1SUP: Surge suppressor

6 Y7SmartSeries servo alarm table

Reason of error alarm and handling method

Error No.: Error Name (Con tent)	Reason	Confirmation method	Handling method
A.020: Parameter and check are abnormal (Abnormal data of internal parameters of servo unit)	The power supply voltage drops instantaneously	Measuring power supply voltage; Confirm the time of the power outage	Set the power supply voltage within the specification range and initialize the parameter Settings (Fn005) .
	The power is turned off during parameter writing	Verify that frequent parameter changes have been made from the upper device	After the initial parameter setting (Fn005), write the parameters again.
	The number of write parameter exceeded the maximum value	When the alarm still occurs after multiple power connections, noise may be the reason	It could be a servo unit failure. Replace the servo unit. Change the parameter writing method.
	Malfunction is caused by noise from AC power supply, grounding, and static electricity	When the alarm still occurs after multiple power connections, noise may be the reason	Take measures to prevent noise interference.
	The components inside the servo unit fault due to gas, water droplets or cutting oil	Confirm the installation environment	It could be a servo unit failure. Replace the servo unit.
A.021: Parameter formatting error (Data form of internal parameters of servo unit is abnormal)	Servo unit fault	When the alarm still occurs after multiple power connections, a servo fault may have occurred	It could be a servo unit failure. Replace the servo unit.
	The software version of the written parameter is newer than the software version of the servo unit where the alarm occurred	Use Fn012 to check whether the software version is the same. If the version is different, an alarm may occur	Write the parameters of other servo units with the same software version and model, and then switch on the power.
A.022: The system and verification are abnormal (Data of internal parameter of servo unit is abnormal)	The power supply voltage drops instantaneously	Measuring supply voltage	It could be a servo unit failure. Replace the servo unit.
	The power was turned off when setting the auxiliary function	Confirm the time of the power off	It could be a servo unit failure. Replace the servo unit.
A.030: The main circuit is detected faulty	Servo unit fault	When the alarm still occurs after multiple power connections,	It could be a servo unit failure. Replace the servo unit.
	Servo unit fault	—	It could be a servo unit failure. Replace the servo unit.
A.040: Parameter setting abnormal (Beyond the set range)	The servo unit capacity does not match the servo motor capacity	Confirm the capacity and combination of servo unit and servo motor	Make the servo unit and servo motor capacity match each other.
	Servo unit fault	—	It could be a servo unit failure. Replace the servo unit.
	Outside the parameter setting range	Confirm the range of parameters	Changed parameter the value within the set range.
A.041: Frequency division pulse output setting is abnormal	The set value of the electronic gear ratio is outside the set range	Verify that the electronic gear ratio is $0.001 < (Pn78C/Pn78E) < 4000$	Set the electronic gear ratio to $0.001 < (Pn78C/Pn78E) < 4000$.
	The number of frequency division pulse of encoder (Pn212) does not satisfy the set range and set conditions	Confirm Pn212	Set Pn212 to the appropriate value.
A.042*: Parameter combination abnormal	The speed of the program JOG running (Fn004) is not within the set range due to changing the electronic gear ratio (Pn78C/Pn78E) or servo motor	Check whether the formula *1 is valid	Reduce the value of electronic gear ratio (Pn78C/Pn78E).
	The program JOG running speed (Fn004) does not satisfy the set range due to the change of program JOG moving speed (Pn533)	Check whether the formula *1 is valid	Increase the value of the program JOG speed (Pn533).
	The movement speed of advanced automatic tuning is not satisfying the set range due to change of electronic gear ratio (Pn78C/Pn78E) or servo motor	Check whether the formula *1 is valid	Reduce the value of electronic gear ratio (Pn78C/Pn78E).
A.044: Semi-closed loop/full closed loop parameter setting error	The fully closed loop module is inconsistent with the setting of Pn002.3	Confirm the Settings for Pn002.3	Make the full closed-loop module conform to the setting of Pn002.3.
A.050: Combination error (Outside capacity range of combinable motors)	The capacity of the servo unit does not match the capacity of the servo motor	Confirm $\frac{1}{4} \leq \frac{\text{the capacity of the motor}}{\text{the capacity of the servo}} \leq 4$	Make the servo unit and servo motor capacity match each other.
	Encoder fault	Replace with other servomotors to ensure the alarm does not occur again	Replace the servo motor (Encoder) .
	Servo unit fault	—	It could be a servo unit failure. Replace the servo unit.
A.051: The product does not support alarm	The unsupported serial conversion unit, encoder, and external encoder are connected to the servo unit	Confirm the product	Change to a matching combination.
A.0b0: Servo ON instruction invalid alarm	After performing the motor power-on auxiliary function, the servo ON (/S-ON) signal is input from the outside	—	Power on the servo unit again or perform software reset.

Error No.: Error Name (Con tent)	Reason	Confirmation method	Handling method
A.100: Overcurrent detection (Overcurrent flows through the power transistor or heat sink overheating)	The main circuit cable is connected incorrectly or in poor contact	Check whether the cable connection is correct	Modify cable connections.
	A short circuit or ground fault occurs inside the main circuit cable	Check whether short circuit occurs between U/V/W phases and the grounding of the cable.	The cable may be short-circuited. Replace the cable.
	Short circuit or ground short circuit occurs inside the servo motor	Check whether there is short circuit between the U/V/W phase and the grounding of the motor terminal.	It could be a servo motor failure. Replace the servo motor.
	Short-circuit or grounding occurs inside the servo unit	Confirm whether short circuit occurs between U/V/W phase and U/V/W and ground of the servo motor connection terminal of the servo unit.	It could be a servo unit failure. Replace the servo unit.
	Regenerator resistor wiring error or poor contact	Check whether the cable connection is correct	Modify cable connections.
	Dynamic brake (emergency stop due to DB, servo unit) is used frequently, or DB overload alarm occurs	Check the DB resistance power consumption (Un00B) to determine the DB frequency. Or use the display of alarm record (Fn000) to confirm whether DB overload alarms A.730, A.731 have occurred.	Change the selection, operation method and mechanism of servo unit to reduce DB usage frequency.
	The regenerative resistance value is too high and exceeds Regenerative processing capacity	Use the regenerative load rate (Un00A) to confirm the frequency of the regenerative resistance	Considering the operating conditions and load, then confirm regenerative resistance value again.
	The regenerative resistance value of servo unit is too small	Use the regenerative load rate (Un00A) to confirm the frequency of the regenerative resistance	Change the regenerative resistance value to a value above the minimum allowable resistance value of the servo unit.
	High load is borne when the servo motor stops or runs at low speed	Verify that the operating conditions are outside the specifications of the servo drive.	Reduce the load on the servo motor or operate at a higher speed.
	Abnormal movements caused by noise	Improve wiring, installation, and other noise environment, confirm whether the effect	Take measures to prevent noise, such as correct FG wiring. In addition, the size of FG wire should be the same as the size of "servo unit main circuit wire".
A.300: Regenerative error	Servo unit fault	—	Switch on the power again. there is still an alarm, it could be a servo unit failure. Replace the servo unit.
	Set the regenerative resistance capacity (Pn600) to a value other than "0" without an external regenerative resistor	Confirm the connection of the external regenerator resistor and the value of Pn600.	Connect an external regenerative resistor, or set Pn600 to 0 when a regenerative resistor is not required.
	There is no external regenerative resistor, and the jumper of the power terminal B2-B3 of the servo unit is loose	Verify that the power terminal jumper is connected	Connect the jumper cables correctly.
	The external regenerative resistor is poorly connected or disconnected	Confirm the wiring of the external regenerator resistor	Connect the external regenerative resistor correctly.
A.320: Regenerative overload	Servo unit fault	—	In the state of not connected to the main circuit power supply, connected to the control power supply, still occur alarm, it could be a servo unit failure. Replace the servo unit.
	The power supply voltage exceeds the specification range	Measuring supply voltage	Set the supply voltage within the specification range.
	External regenerative resistance value or regenerative resistance capacity is insufficient, or in the state of continuous regeneration	Reconfirm the running condition or capacity	Change the regenerative resistance value and regenerative resistance capacity, and adjust the operating conditions again.
	Continuous load bearing, in a state of continuous regeneration	Confirm the load applied to the running servo motor	Discuss the system including servo, machinery and operating conditions.
	The capacity set in parameter Pn600 is smaller than that of the external regenerative resistor	Confirm the regenerator resistor connection and Pn600 value	Correct the set value of parameter Pn600.
A.330: The main circuit power supply is incorrectly connected * Check out when switch on the main circuit power supply	The external regenerative resistance value is too large	Verify that the regenerative resistance value is correct	Change it to the correct resistance value and capacity.
	Servo unit fault	—	It could be a servo unit failure. Replace the servo unit.
	The power supply voltage inside the servo unit is too high, and the regenerative resistor is disconnected	Measuring the resistance value of regenerating resistor	Replace the servo unit when using the regenerative resistor built in the servo unit. When using an external regenerative resistor, replace the regenerative resistor.
	When setting the AC power input, the DC power is input	Check whether the power supply is DC	Make the set value of the power supply consistent with the power supply used.
	When setting the DC power input, the AC power is input	Check whether the power supply is AC	Make the set value of the power supply consistent with the power supply used.
A.330: The main circuit power supply is incorrectly connected * Check out when switch on the main circuit power supply	Set the regenerative resistance capacity (Pn600) to a value other than "0" without an external regenerative resistor	Confirm the connection of the external regenerator resistor and the value of Pn600	Connect an external regenerator resistor or set Pn600 to 0 when an external regenerator resistor is not required.
	There is no external regenerative resistor, and the jumper of the power terminal B2-B3 of the servo unit is loose	Verify that the power terminal jumper is connected	Connect the jumper cables correctly.
	Servo unit fault	—	It could be a servo unit failure. Replace the servo unit.

Error No.: Error Name (Con tent)	Reason	Confirmation method	Handling method
A.400: overvoltage (Overvoltage is detected through the power supply section of the main circuit of the servo unit)	· AC200V servo unit and AC power supply voltage above 290V, or AC400V servo unit detects power supply voltage above AC580V · The servo unit and DC power supply voltage of AC200V are above 410V, and the DC power supply voltage of over 830V is detected by the servo unit of AC400V	Measure voltage of power supply	Adjust the AC/DC power supply voltage to range of the product specifications.
	The power supply is unstable or affected by lightning strikes	Measure voltage of power supply	Improve the power supply condition, set the surge suppressor, etc., and then switch on the power again, still occur alarm, it could be a servo unit failure. Replace the servo unit.
	When the AC power supply voltage is higher than the specification range, the acceleration and deceleration motion is carried out	Confirm the power supply voltage and the speed and torque in operation	Adjust the AC power supply voltage to range of the product specifications.
	The external regenerative resistance value is larger than the operating condition	Confirm operating conditions and regenerative resistance values	Considering the operating conditions and load, the regenerative resistance value should be discussed again.
	Operating in a state with an inertia ratio which above the allowable value	Verify that the moment of inertia ratio is within the allowable value	Extend the deceleration time, or reduce the load.
	Servo unit fault	—	In the state of not connected to the main circuit power supply, connected to the control power supply, still occur alarm, it could be a servo unit failure. Replace the servo unit.
A.410: undervoltage (Check the undervoltage through the power supply section of the main circuit of the servo unit)	AC200V servo unit, AC power supply voltage below 120V AC400V servo unit, AC power supply voltage is below 220V	Measure voltage of power supply	Adjust the supply voltage to the normal range.
	The power supply voltage drops during operation	Measure voltage of power supply	Increase the power capacity.
	Instantaneous power cut	Measure voltage of power supply	If the instantaneous outage hold time (Pn509) is changed, set it to a smaller value.
	The fuse of the servo unit has blown	—	Replace the servo unit and connect the reactor before using the servo unit.
Servo unit fault	—	It could be a servo unit failure. Replace the servo unit.	
A.450: Main circuit capacitor overvoltage	Servo unit fault	—	Replace the servo unit.
A.510: Overspeed (motor speed above maximum speed)	The U, V, W phase sequence of the motor connection is wrong	Confirm the connection of servo motor	Confirm whether there is any problem with motor wiring.
	The instruction input value exceeded the overspeed value	Confirm input instruction	Decrease the command value, or adjust the gain.
	The motor speed exceeds the maximum speed	Confirm motor speed waveform	Reduce speed instruction input gain, adjust servo gain, or adjust operating conditions.
Servo unit fault	—	It could be a servo unit failure. Replace the servo unit.	
A.511: Frequency division pulse output overspeed	The output frequency of the frequency division pulse is too large and exceeds the limit value	Confirm the output Settings of the frequency division pulse	Decrease the frequency division pulse number (Pn212) setting for encoder.
	The motor speed is too high, and the output frequency of the frequency division pulse exceeds the limit value	Confirm the output setting and motor speed of the frequency division pulse	Reduce motor speed.
A.520: Vibration alarm	Abnormal motor speed vibration is detected	Confirm the abnormal sound of the motor and the speed and torque waveform during operation	Reduce motor speed. Or reduce the speed loop gain (Pn100).
	The value of the moment of inertia ratio (Pn103) is larger than the actual value or has a large change	Confirm the moment of inertia ratio	Set the moment of inertia ratio correctly (Pn103).
A.521: Advanced automatic tuning alarm (Vibration detected in single parameter tuning, EasyFFT, no adjustment power)	The motor vibrates greatly when using the free adjustment function	Confirm motor speed waveform	Reduce the load below the allowable moment of inertia ratio, or raise the load value of the free adjustment value setting (Fn200), or reduce the rigidity value.
	In the process of single parameter tuning and EasyFFT, the motor vibrates greatly	Confirm motor speed waveform	Implement the handling measures in each functional operation step.
A.710: overload (Instantaneous maximum load)	Motor wiring, encoder wiring or connection are abnormal	Confirm wiring	Confirm whether there is any problem with motor wiring and encoder wiring.
	Motor operation exceeds the overload protection characteristic	Confirm the overload characteristics of the motor and running instructions	The load condition and operation condition should be discussed again or reduce motor capacity.
A.720: overload (Continuous maximum load)	The motor is not operated due to mechanical factors, resulting in excessive load during operation	Confirm running instructions and motor speed	Improve mechanical factors.
	Servo unit fault	—	It could be a servo unit failure. Replace the servo unit.
A.730: A.731: DB overload (The power consumption of dynamic brake is detected to be too high)	The motor is being driven by external forces	Confirm running status	Do not drive the motor through external forces.
	The rotational energy of the DB at stop exceeds the capacity of the DB resistance	Check the DB resistance power consumption (Un00B) to determine the DB frequency	Try the following measures · Reduce the command speed of the servo motor. · Reduce the moment of inertia ratio. · Reduce the number of DB stops.
Servo unit fault	—	It could be a servo unit failure. Replace the servo unit.	

Error No.: Error Name (Con tent)	Reason	Confirmation method	Handling method
A.740: Impulse current limiting resistor overload (The frequency of main circuit power supply is too high)	The number of times the impulse current limiting resistance exceeds the ON/OFF limit of the main circuit power supply	—	Reduce the ON/OFF frequency of the main circuit power supply.
	Servo unit fault	—	It could be a servo unit failure. Replace the servo unit.
A.7A0: Heat sink overheating (Heat sink temperature of servo unit exceeds 100° C)	Ambient temperature is too high	Use a thermometer to measure the ambient temperature	Improve the installation condition of servo unit and reduce the ambient temperature.
	The operation was performed after resetting the overload alarm several times by turning off the power	The overload alarm is recognized by the display of the alarm record (Fn000)	Change the reset method of the alarm.
	The load is too large or exceeds the regenerative processing capacity at running	The load in operation is confirmed by the cumulative load rate Un009, and the regenerative processing capacity is confirmed by the regenerative load rate (Un00A)	The load condition and operation condition should be discussed again.
	The mounting direction and spacing between servo unit and other servo units are unreasonable	Confirm the installation status of the servo unit	Install according to servo unit installation standards.
Servo unit fault	—	It could be a servo unit failure. Replace the servo unit.	
A.7AB: Servo unit built-in fan stops	The fan inside the servo unit stops rotating	Confirm there's no foreign object stuck	If an alarm still occurs after the foreign object is removed, it could be a servo unit failure. Replace the servo unit.
A.810: Encoder backup alarm * Checked only when absolute value encoder is connected * Check out on the encoder side	Power on the absolute value encoder for the first time	Check whether it is powered on for the first time	Perform the encoder setting operation (Fn008).
	The encoder cable was removed and then reconnected	Check whether it is powered on for the first time	Confirm the connection of the encoder and set up the encoder (Fn008)
	The control power supply (+5V) of the servo unit and the battery power supply are faulty	Verify that the battery and plug status of the encoder plug are correct	After restoring the power supply to the encoder (replacing the battery, etc.), set up the encoder (Fn008).
Absolute value encoder fault	—	Replace the servo motor if the alarm cannot be disarmed even if the setting operation is performed again.	
Servo unit fault	—	It could be a servo unit failure. Replace the servo unit.	
A.820: Encoder sum check alarm * Check out on the encoder side	Encoder fault	—	· Absolute encoder time. If the (Fn008) encoder is set again and alarms still occur frequently, it could be a servo unit failure. Replace the servo unit. · For rotary absolute encoder or incremental encoder, it could be a servo motor failure. Replace the servo motor.
	Servo unit fault	—	It could be a servo unit failure. Replace the servo unit.
A.830: Encoder battery alarm (Absolute encoder battery voltage below the specified value)	The battery is improperly connected or disconnected	Check the battery connection	Connect the battery properly.
	Battery voltage below the specified value (2.7V)	Measure the voltage of the battery	Replace the battery.
Servo unit fault	—	It could be a servo unit failure. Replace the servo unit.	
A.840: Encoder data alarm * Check out on the encoder side	Encoder malfunction	—	Switch on the power again, there is still an alarm, it could be a servo motor failure. Replace the servo motor.
	Encoder malfunction due to noise and other interference	—	Properly connect wiring of the encoder periphery. (Separate encoder cable from servo motor main circuit cable, grounding treatment, etc.)
A.850: Encoder overspeed * Check when the control power is switched on * Check out on the encoder side	When the control power is switched on, the servo motor rotates at a speed of more than 200 rpm	Confirm the motor speed when powered on by the motor rotation speed monitor (Un000)	Adjust the servo motor speed to less than 200 rpm, and then switch on the control power +
	Encoder fault	—	Switch on the power again, there is still an alarm, it could be a servo motor failure. Replace the servo motor.
	Servo unit fault	—	Switch on the power again, there is still an alarm, it could be a servo unit failure. Replace the servo unit.
A.860: Encoder overheating * Checked only when absolute value encoder is connected * Check out on the encoder side	The ambient temperature of the servo motor is too high	Measure the ambient temperature of the servo motor	Adjust the ambient temperature of the servo motor below 40° C.
	The servo motor operates at a load which exceed the rated value	Motor load is confirmed by cumulative load rate (Un009)	Adjust the load of the servo motor to within the rated value before running.
Encoder fault	—	Switch on the power again, there is still an alarm, it could be a servo motor failure. Replace the servo motor.	
Servo unit fault +	—	Switch on the power again, there is still an alarm, it could be a servo unit failure. Replace the servo unit.	
A.8A0: External encoder error	Motor running, absolute value external encoder origin setting failed.	Before setting the origin position, confirm that the motor is not running by the full closed-loop feedback pulse counter monitor (Un00E)	Stop the motor when setting the origin position.
	External encoder error	—	Replace the external encoder.
A.8A1: The external encoder module error	External encoder error	—	Replace the external encoder.
	The serial conversion unit error	—	Replace the serial conversion unit.
A.8A2: The external encoder sensor error (Incremental type)	External encoder error	—	Replace the external encoder.

Error No.: Error Name (Content)	Reason	Confirmation method	Handling method
A.8A3: The external encoder position error (Absolute value)	Absolute external encoder error	—	It is possible that the absolute value external encoder fault. Please take corresponding measures according to the manufacturer's instruction manual.
A.8A5: External encoder overspeed error	Detected overspeed of external encoder	Confirm the maximum speed of the external encoder	Use the external encoder below its maximum speed.
A.8A6: External encoder overheating error	Detected overheating of external encoder	—	Replace the external encoder.
A.b31: Current detection error 1	U-phase current detection loop error	—	Switch on the power again. there is still an alarm, it could be a servo unit failure. Replace the servo unit.
A.b32: Current detection error 2	V-phase current detection loop error	—	Switch on the power again. there is still an alarm, it could be a servo unit failure. Replace the servo unit.
A.b33: Current detection error 3	The current detection loop error	—	Switch on the power again. there is still an alarm, it could be a servo unit failure. Replace the servo unit.
	The main circuit cable of servo motor is disconnected	Confirm whether the main circuit cable of the servo motor is disconnected	Repair the motor cable.
A.bF0: System alarm 0	Servo unit fault	—	Switch on the power again. there is still an alarm, it could be a servo unit failure. Replace the servo unit.
A.bF1: System alarm 1	Servo unit fault	—	Switch on the power again. there is still an alarm, it could be a servo unit failure. Replace the servo unit.
A.bF2: System alarm 2	Servo unit fault	—	Switch on the power again. there is still an alarm, it could be a servo unit failure. Replace the servo unit.
A.bF3: System alarm 3	Servo unit fault	—	Switch on the power again. there is still an alarm, it could be a servo unit failure. Replace the servo unit.
A.bF4: System alarm 4	Servo unit fault	—	Switch on the power again. there is still an alarm, it could be a servo unit failure. Replace the servo unit.
A.C10: Prevent out of control detection * Check out when the servo is ON	The U, V, W phase sequence of the motor connection is wrong	Confirm motor wiring	Confirm whether there is any problem with motor wiring.
	Encoder fault	—	If there is no problem with the motor wiring, switch on the power again. there is still an alarm, it could be a servo motor failure. Replace the servo motor.
	Servo unit fault	—	Switch on the power again. there is still an alarm, it could be a servo unit failure. Replace the servo unit.
A.C80: Encoder clear abnormal (The upper limit of the number of turns is abnormal)	Encoder fault	—	Switch on the power again. there is still an alarm, it could be a servo motor failure. Replace the servo motor.
	Servo unit fault	—	Switch on the power again. there is still an alarm, it could be a servo unit failure. Replace the servo unit.
A.C90: Encoder communication error	Poor contact of encoder connector, or wrong plug connection	Confirm the status of the port used by the encoder connection	Insert encoder plug again to confirm the encoder connection.
	Encoder cable breaks, short circuit, or uses a cable that exceeds the specified impedance	Confirm the status of the encoder cable	Use the encoder cable as required specification.
	Corrosion caused by temperature, humidity and gas; Short circuit caused by water drop and cutting oil; Poor plug contact due to vibration	Confirm the operating environment	Improve the operating environment and replace the cable. Even if there is no improvement, replace the servo unit.
	Malfunction caused by noise interference.	—	Correctly connect wiring of the encoder periphery (separate the encoder cable from the servo motor main circuit cable, ground treatment, etc.).
	Servo unit fault	—	If no alarm occurs when the servo motor is connected to other servo units and the control power is switched on, it could be a servo unit failure. Replace the servo unit.
A.C91: Encoder communication position data acceleration is abnormal	Encoder cable may be snagged, cladding damaged and signal line interfered	Confirm the status of encoder cables and access ports	Confirm whether there is a problem with the laying of encoder cables.
	Encoder cables are bundled or too close to high current wires	Confirm the setting status of the encoder cable	Lay the encoder cable in a position where it will not be subjected to surge voltage.
	The potential varies of FG due to the influence of the equipment (welding machine, etc.) at the motor side	Confirm the setting status of the encoder cable	Ground the machine to prevent shunt to the encoder side FG.
A.C92: The encoder communication timer is abnormal	The signal line of the encoder is interfered	—	Implement anti-jamming countermeasures for encoder wiring.
	Encoder withstand excessive vibration impact	Confirm service condition	Reduce the vibration of the machine. Or install the servo motor correctly.
	Encoder fault	—	Switch on the power again. there is still an alarm, it could be a servo motor failure. Replace the servo motor.
	Servo unit fault	—	Switch on the power again. there is still an alarm, it could be a servo unit failure. Replace the servo unit.

Error No.: Error Name (Content)	Reason	Confirmation method	Handling method
A.CA0: Encoder parameter abnormal	Encoder fault	—	Switch on the power again. there is still an alarm, it could be a servo motor failure. Replace the servo motor.
	Servo unit fault	—	Switch on the power again. there is still an alarm, it could be a servo unit failure. Replace the servo unit.
A.Cb0: The encoder loopback check is abnormal	Encoder wiring error, poor contact	Check the encoder wiring	Check whether the cable to the encoder is faulty
	Encoder cable specifications are different, subject to noise interference	—	Change the cable specifications to double stranded cable or double stranded overall shielded cable. The core wire is more than 0.12mm ² and tinned soft copper stranded cable.
	The connection distance of encoder cable is too long, which is interfered by noise	—	The maximum connection distance is 50m.
	The potential varies of FG due to the influence of the equipment (welding machine, etc.) at the motor side	Confirm the setting status of the encoder cable	Ground the machine to prevent shunt to the encoder side FG.
	Encoder withstand excessive vibration impact	Confirm service condition	Reduce the vibration of the machine. Or install the servo motor correctly.
	Encoder fault	—	Switch on the power again. there is still an alarm, it could be a servo motor failure. Replace the servo motor.
A.CC0: The upper limit of the number of turns is inconsistent	Servo unit fault	—	Switch on the power again. there is still an alarm, it could be a servo unit failure. Replace the servo unit.
	The upper limit for DD motor rotation (Pn205) is different from the upper limit for encoder rotation	Confirm Pn205	Set the Pn205 correctly (0 ~65535) .
	The upper limit of the number of revolutions of the encoder is different from the parameter of the servo unit, or this parameter is changed	Confirm the value of servo unit Pn205	Change the Setting Fn013 when an alarm is occurring.
A.CF1: Feedback Communication error of optional module (receiving error)	Incorrect connection or poor contact of the cable between serial conversion unit and servo unit	Confirm the cables to the external encoder	Correctly connect cables between serial conversion unit and servo unit.
	No specified cable is used between serial conversion unit and servo unit	Confirm cable specifications for external encoder	Use the correct specified cable.
	The cable between the serial conversion unit and the servo unit is too long	Change the length of the cable connecting the serial conversion unit	Make the cable length between serial conversion unit and servo unit within 20m.
	The cable cladding between serial conversion unit and servo unit is damaged	Confirm that the serial conversion unit is connected to the cable	Replace the cable between serial conversion unit and servo unit.
A.d00: Excessive position deviation (When the servo is OFF, the position deviation exceeds the position deviation alarm value (Pn520).)	The connection of U, V and W of servo motor is incorrect	Confirm the connection of main circuit cable of servo motor	Check whether the motor cable or encoder cable has poor contact and other problems.
	The frequency of the position instruction is too high	Try to decrease the command pulse rate before running	Reduce the position command pulse frequency or command acceleration, or adjust the electronic gear ratio.
	Position instruction acceleration is too large	Try to decrease the command acceleration before running	Add smoothing functions of the time constant of position instruction acceleration and deceleration (Pn216).
	The alarm value of 'excessive position deviation' (Pn520) is too low relative to the operating conditions	Verify that the position deviation alarm value (Pn520) is appropriate	Set the Pn520 parameter correctly.
A.d01: Excessive position deviation alarm when servo ON	Servo unit fault	—	Switch on the power again. There is still an alarm, it could be a servo unit failure. Replace the servo unit.
A.d02: Warning of excessive position deviation caused by speed limit when servo ON	When the position deviation is above the set value of Pn526, the servo ON	Confirm the position deviation of the servo ON (Un008)	To clear the position deviation when the servo ON or set the correct alarm value of excessive position deviation (Pn526) when the servo ON.
	When the servo is ON in the position deviation accumulation state, the speed is limited by the speed limit value (Pn529) when the servo is ON. Input a position command in this state exceeds the set value of the 'excessive position deviation' alarm (Pn520).	—	To clear the position deviation when the servo ON or set the correct alarm value of excessive position deviation (Pn526) when the servo ON or set the servo ON speed limit value (Pn529) to the correct value.
A.d10: Excessive position deviation between Motor - load	Motor rotation direction is opposite to the external encoder mounting direction	Confirm the motor rotation direction and the external encoder installation direction	Reverse the mounting direction of the external encoder, or set the rotation direction of the 'Method of Using the External Encoder (Pn002.3)' to the opposite direction.
	The load position of the worktable, etc., and the installation failure of the external encoder junction	Confirm external encoder connection	Mechanical binding again.
	Poor connection between servo unit and STO module	Confirm the connection between the servo unit and the STO module	Properly connect STO modules.
A.E71: STO module Detect failure alarm	Removed the STO module	-	Run Fn014 (clear the optional module check out result) through the digital operator or SigmaWin+, then power on again.
	STO module is faulty	-	Replace STO module.
	Servo unit fault	-	Replace servo unit.

Error No.: Error Name (Content)	Reason	Confirmation method	Handling method
A.E72: Feedback optional module Detect failure alarm	Poor connection between servo unit and feedback optional module	Confirm the connection between the servo unit and the feedback optional module	Correctly connected feedback optional modules.
	Removed the feedback optional module	—	Run Fn014 (clear the optional module check result) and power on again.
	Feedback optional module is faulty	—	Replace the feedback optional module.
A.E74: Alarm for unsupported STO module	Servo unit fault	—	Replace servo unit.
	STO module is faulty	—	Replace STO module.
A.E75: Alarm for unsupported feedback optional module	An unsupported STO module is connected	Refer to the product catalog of connected servo units and STO modules	Connect the supported STO modules.
	Feedback optional module is faulty	—	Replace the feedback optional module.
A.Eb1: The signal input time of the security function is abnormal	An unsupported feedback optional module connected	Refer to the product catalog of connected servo units and feedback optional modules	Connect the supported feedback optional modules.
	The startup time difference between the input signals /HWBB1 and /HWBB2 of the hardwired base blocking function is more than 10 seconds	Measure the time difference between the two input signals	May be /HWBB1, /HWBB2 output signal loop fault, machine fault, servo unit input signal loop fault, input signal cable broken. Confirm the fault or disconnection.
A.F10: Power phase loss (In the ON state of the main power supply, the low voltage state of a phase in the R, S, T phase lasts for more than 1 second) when the main circuit power supply is switched on	The three-phase power cable is poor connected	Confirm power cables	Check whether the power cable is faulty.
	The three-phase power supply is unbalanced	Measure the voltage of each phase of the three-phase power supply	Correct unbalance of power supply (transpose phase).
	Without the parameter setting of single-phase input (Pn00B.2 = 1), the single-phase power supply is directly input	Confirm power and parameter Settings	Set power input and parameters correctly.
	Servo unit fault	—	Switch on the power again. there is still an alarm, it could be a servo unit failure. Replace the servo unit.
A.F26	The torque instruction reached its maximum value	—	Properly connect the UVW power wires of the motor
A.F28	Position instruction abnormal	Check the values of 6064 and 607A	Input position instructions correctly
FL-1*2: System alarm	Servo unit fault	—	Switch on the power again. there is still an alarm, it could be a servo unit failure. Replace the servo unit.
FL-2*2: System alarm	Servo unit fault	—	Switch on the power again. there is still an alarm, it could be a servo unit failure. Replace the servo unit.

Reason of error alarm and handling method

Warning No.: Warning name (Content)	Reason	Confirmation method	Handling method
A.900: Excessive position deviation	The connection of U, V and W of servo motor is incorrect	Confirm the connection of main circuit cable of servo motor	Check whether the motor cable or encoder cable has poor contact and other problems.
	The servo unit gain is low	Check if the gain of the servo unit is too low	Improve servo gain through advanced automatic tuning.
	The frequency of the position instruction pulse is too high	Try to decrease the command pulse rate before running	Reduce the position command pulse frequency or command acceleration, or adjust the electronic gear ratio.
	Position instruction acceleration is too large	Try to decrease the command acceleration before running	Add smoothing functions of the time constant of position instruction acceleration and deceleration (Pn216/Pn217).
	The excessive position deviation alarm value (Pn520) is too low relative to the operating conditions	Verify that the excessive position deviation alarm value (Pn520) is appropriate	Set the Pn520 correctly.
A.901: Excessive position deviation when servo ON	Servo unit fault	—	Switch on the power again. there is still an alarm, it could be a servo unit failure. Replace the servo unit.
	When servo ON, the accumulated position deviation exceeds set ratio $Pn520 \times Pn51E / 100$	—	To clear the position deviation when the servo is OFF or set the appropriate position deviation excessive warning value when the servo is ON (Pn528).
A.910: Overload (Then Warning before it becomes overload alarm (A.710 A.720))	Motor wiring, encoder wiring or poor connection	Confirm connection	Confirm whether there is any problem with motor wiring and encoder wiring.
	Motor operation exceeds the overload protection characteristic	Confirm motor overload characteristics and operation instructions	Reconsider the load and operating conditions. Or, increase the motor capacity.
	The motor is not driven due to mechanical factors, resulting in excessive load during operation	Confirm instructions and motor speed	Improve mechanical factors.
A.911: Vibration	Servo unit fault	—	It could be a servo unit failure. Replace the servo unit.
	Detect abnormal vibration in motor operation	Confirm the abnormal sound of the motor and the speed and torque waveform during operation	Reduce motor speed or servo gain by single parameter tuning.
A.911: Vibration	The value of the rotary inertia ratio (Pn103) is larger than the actual value or it has a large change	Confirm the rotary inertia ratio	Set the rotary inertia ratio correctly (Pn103).

Warning No.: Warning name (Content)	Reason	Confirmation method	Handling method
A.920: Regenerative overload (The warning before it becomes regenerative overload alarm (A.320))	The power supply voltage exceeds the specification range.	Measure voltage of power supply +	Set the voltage of power supply within the specification range.
	External regenerative resistance value, servo unit capacity or regenerative resistance capacity is insufficient, or in continuous regenerative state	Reconfirm running conditions or capacity (capacity selection software HCServoWorks, etc.)	Change the regenerative resistance value, regenerative resistance capacity, or servo unit capacity. The operating conditions were adjusted again (capacity selection software HCServoWorks, etc.).
A.921: DB overload (The warning before it becomes DB overload (A.731))	Continuous bearing of negative load, in a state of continuous regeneration	Confirm the load applied to the running servo motor	Rediscuss the system including servo, machinery and operating conditions.
	The motor is being driven by external forces	Confirm operation status	Do not drive the motor through external forces.
A.930: Battery failure of absolute value encoder (Absolute value encoder battery voltage below the specified value) * Check out when connecting absolute value encoder only	The rotational energy of the DB at stop exceeds the capacity of the DB resistance	Check the DB resistance power consumption (Un00B) to determine the DB frequency	Try the following measures · Reduce the command speed of the servo motor. · Reduce the moment of inertia ratio. · Reduce the number of DB stops.
	Servo unit fault	—	It could be a servo unit failure. Replace the servo unit.
A.941: Changed the parameters that need to repower	The battery is improperly connected or disconnected	Check the battery connection	Connect the battery properly.
	Battery voltage below the specified value (2.7V)	Measure the voltage of the battery	Replace the battery.
A.971: Undervoltage	Servo unit fault	—	It could be a servo unit failure. Replace the servo unit.
	Changed the parameters that need to repower	Changed the parameters that need to be repower	Repower servo drive
A.971: Undervoltage	200V servo unit, AC power supply voltage below 140V, 400V servo unit, AC power supply voltage below 280V	Measure voltage of power supply	Adjust the supply voltage to the normal range.
	The power supply voltage drops during operation	Measure voltage of power supply	Increase the power capacity.
	Instantaneous power cut	Measure voltage of power supply	If the instantaneous outage hold time (Pn509) is changed, set it to a smaller value.
	The fuse of the servo unit has blown	—	Replace the servo unit and connect the reactor before using the servo unit.
A.9A0: Overtravel (Overtravel status was detected.)	Servo unit fault	—	It could be a servo unit failure. Replace the servo unit.
	Overtravel was detected while the servo was ON.	Check the status of the overtravel signals on the input signal monitor(Un005).	The reason of error and handling method can be judged from the action and state of the servo motor ". In addition, if the overtravel signal cannot be confirmed with the input signal monitor (Un005), a transient overtravel may be detected. Take the following measures · Do not send instructions from the upper device to the position which is overtravel. · Confirm the signal connection of the overtravel signal. · Adopt anti-interference countermeasures.
A.9B0	The setting of soft limit is incorrect.	Check whether the 607D value is correct	Set the value of 607D in the correct range
A.9B1	The setting of origin offset is incorrect.	Check whether the 607D and 607C values are correct	Set the values of 607D and 607C in the correct range
A.9B2	Synchronization frame data is lost	Check whether the twisted-pair shielded communications cable is used. Check whether the driver is properly grounded;	1. Use twisted-pair shielded cables. 2. Connect cables according to standard wiring instructions; 3. After setting the pre-used synchronization period, switch the drive EtherCAT communication state machine to the running mode. 4. If the synchronization period of the master station has a large error, adjust the synchronization loss fault tolerance Pn785 of the master station or the slave station
A.9B3	EtherCAT communication was interrupted	Check whether the twisted-pair shielded communications cable is used. Check whether the driver is properly grounded;	1. Use twisted-pair shielded cables. 2. Connect cables according to standard wiring instructions; 3. After setting the pre-used synchronization period, switch the drive EtherCAT communication state machine to the running mode. 4. If the synchronization period of the master station has a large error, adjust the synchronization loss fault tolerance Pn785 of the master station or the slave station
A.9B4	EtherCAT network initialization failed.	The device configuration file is not burned. The servo drive is faulty	Burn the corresponding xml file, or replace the servo drive
A.9B5	Current loop status alarm	The torque instruction is less than 30%, and the motor is stopping	Set torque instructions and maximum torque limits correctly
A.9B7	The enable condition is not satisfied	If the hardware base is not locked, the device cannot be enabled if the conditions are not satisfied. Or the bus voltage is undervoltage	Confirm whether the bus voltage supply is normal; Check whether the CN3 port is normal
A.9B8	Any input of security interface is not connected to +24V	Check whether the security function uses signal STO(CN3) properly	Restore the secure interface after ensuring that it is secure
A.9B9	Emergency stop warning	Check the Pn515.3 E-Stop signal allocation and whether the DI terminal logic is set to valid.	Check the operating mode and release the DI brake signal when it is safe

Function code definition

Function Definition of the digital input terminal (DI)		
Function name	Name description	Function instruction
P-OT	Forward Drive Prohibit	When the mechanical movement exceeds the movable range limit switch action, enter the overtravel protection function Valid: Positive limit, positive motion is prohibited Invalid: Normal range, positive motion is allowed
N-OT	Reverse Drive Prohibit	When the mechanical movement exceeds the movable range limit switch action, enter the overtravel protection function Effective: Negative limit, negative motion is prohibited Invalid: Normal range, negative motion is allowed
/HomeSwitch	Homing signal	Invalid: Homing not completed Valid: Homing completed
EXT	Probe signal	Invalid: Position latch is not performed Valid: Position latch using probe
BK	Brake signal	Invalid: Brake action Valid: Brake does not act