



HPPD1490019-00A
Date 2024-07-30
CN 安装说明
EN Instruction Sheet

1. 安全注意事项 (Safety precautions)

本说明书设计产品均为开放型外壳设计。要求用户使用产品时，务必将产品安装于具有防尘、防潮以及免于电击 / 冲击等意外的控制柜内，并且需要设置保护措施以防止非维护人员不当操作或意外导致设备故障或损坏，造成不可避免的人员危险和财产损失。

The products involved are all open-type housing designs. Therefore they should be installed in a control cabinet that is free of airborne dust, humidity, electric shock, and vibration. The cabinet should prevent non-maintenance staff from operating the products or accidents from happening in case danger and damage may occur on the products.

更详细的信息请参考 X5 系列 EtherCAT 总线版本硬件手册。
Please refer to the X5 series EtherCAT bus hardware manual for more detailed information.

2. 适用型号 (Applicable model)

功率 (Power)	型号* (Model)	功率 (Power)	型号 (Model)
100W	SV-X5E(F)B010A-AS-00	1.5kW	SV-X5E(F)B150A-AS-00
200W	SV-X5E(F)B020A-AS-00	2kW	SV-X5E(F)B200A-AS-00
400W	SV-X5E(F)B040A-AS-00		SV-X5E(F)B200T-AS-00
750W	SV-X5E(F)B075A-AS-00	2.5kW	SV-X5E(F)B250A-AS-00
1kW	SV-X5E(F)B100A-AS-00	3kW	SV-X5E(F)B300T-AS-00

*注：型号 SV- □ A- □ 中 A 表示电压规格 220V，SV- □ T- □ 中 T 表示电压规格 380V。SV-X5E □ - □ 中 E 表示标准型，SV-X5F □ - □ 中 F 表示全功能型。
*Note: "A" in SV- □ A- □ stands for the voltage specification of 220V, "T" in SV- □ T- □ stands for the voltage specification of 380V, "E" in SV-X5E- □ stands for standard type, and "F" in SV-X5F □ - □ stands for the full-function type.

3. 安装说明 (Installation instructions)

3.1 控制柜安装 (Installation within a control cabinet)

CN 设备冷却方式为自然冷却或通过加装风扇进行冷却，请保证安装方向与柜壁垂直；请参考右侧示意图，在设备的周围留有足够的空间，建议横向两侧预留 30mm 以上间距。

EN Please install the product perpendicular to the wall and ensure a sufficient cooling effect via natural air or a cooling fan. Please leave enough clearance around the product as shown in the right figure. Please leave a horizontal clearance of more than 30 mm on both sides.

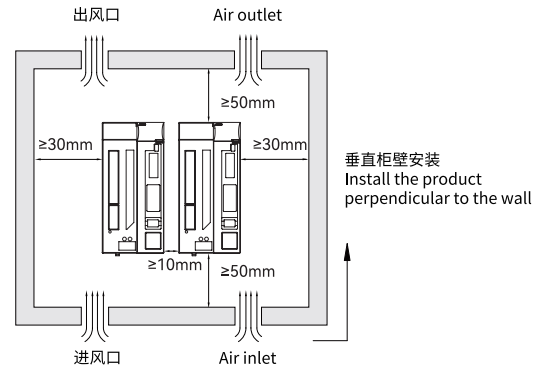

3.2 机柜背板安装 (Cabinet backplane mounting)

CN 按孔位图在机柜背板上开孔，安装输出功率 1kW 及以下的驱动器时，请各使用 2 个 M4 螺丝固定；安装输出功率 1.5kW 及以上的驱动器时，请各使用 3 个 M5 螺丝固定。

EN Drill holes on the back panel of the cabinet according to the hole map. When installing a drive with an output power of 1kW or less, please use two M4 screws to secure it. When installing a drive with an output power of 1.5kW or above, please use three M5 screws to secure it.

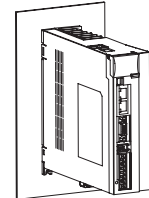
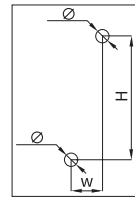

3.3 撬棍使用示意 (Crowbar mounting and dismounting)

CN 撬棍使用如右图所示。

EN The mounting and dismounting of the crowbar are shown in the figures on the right side.

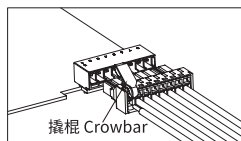

安装撬棍
Install the crowbar

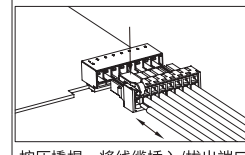

按压撬棍，将线缆插入/拔出端口
Press the crowbar and then insert or unplug a cable into or out of the port where the crowbar is installed.

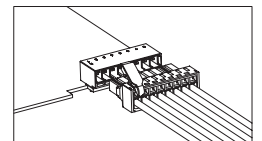

移除撬棍
Remove the crowbar

3.4 可拆卸端子拆装 (Removable terminal block mounting and dismounting)

CN 可拆卸端子拆装如右图所示。

EN The mounting and dismounting of the removable terminal block are shown in the figures on the right side.

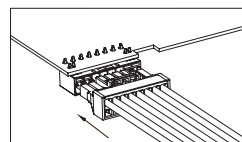

沿箭头所示方向插入端子
Inter the terminal block along the direction indicated by the arrow

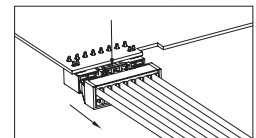

按压锁扣并拔出端子
Press the latch and detach the terminal block

3.5 线缆选型 (Cable selection)

线缆名称(Cable)	线径范围(Wire width) AGV	UL	耐热(Heat resistance)	备注(Note)
动力线缆-750W以下 (Power cable - under 750W)	18	2517	105°C	

动力线缆-1kW以上 (Power cable - over 1kW)	14	2501	105°C	
主回路电源线缆-750W以下 (Main circuit power supply cable - under 750W)	18	1015相当 Equivalent to 1015	105°C	
主回路电源线缆-1kW以上 (Main circuit power supply cable - over 1kW)	14	1015相当 Equivalent to 1015	105°C	
编码器线缆 (Encoder cable)	电源(Power): 22 信号(Signal): 24	—	—	5P(10芯), 屏蔽线最大长度为20m 5P (10 core) Maximum length of the shielding wire: 20m
再生电阻线缆 (Regenerative resistor cable)	18	1015相当 Equivalent to 1015	105°C	
制动线缆 (Brake cable)	18	2517	105°C	1P(2芯) 1P (2 core)
控制回路电源线缆-750W以下 (Control circuit power supply cable - under 750W)	18	1015	105°C	
控制回路电源线缆-1kW以上 (Control circuit power supply cable - over 1kW)	14	1015	105°C	
通讯线缆 (Communication cable)	24	—	—	超五类以上 Above CAT5e

4. 接口及配线说明 (Interface and wiring instructions)

4.1 接口说明 (Interface description)

序号(No.)	项目	Item
1	CN2: STO接口*	CN2: STO interface
2	显示面板	LED display screen
3	CN3: Mini USB	CN3: Mini USB
4	CN4: 总线通讯输入接口	CN4: Bus communication interface (IN)
5	CN5: 总线通讯输出接口	CN5: Bus communication interface (OUT)
6	CN6: 功能I/O信号接口	CN6: Function I/O signal interface
7	CN7: 编码器接口	CN7: Encoder interface
8	控制回路电源输入	Control power supply input
9	主回路电源输入	Main circuit power supply input
10	再生电阻接口	Regenerative resistor interface
11	母线电压负极	Negative polarity of bus voltage
12	伺服电机连接接口	Servo motor connection interface
13	伺服电机接地端子	Servo motor ground terminal
14	母线电源指示灯	Busbar power supply indicator
15	电源接地端子	Power supply ground terminal

*注: 仅全功能型有此接口。

*Note: Only a full-featured model is equipped with this interface.

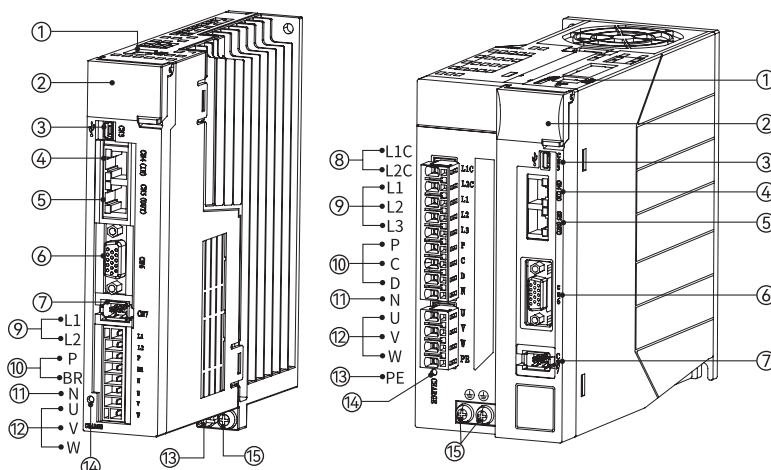

项目(Item)	指示灯颜色	Color	状态	Status	详细说明	Description
母线电源指示灯 (Busbar power supply indicator)	红色	Red	常亮	Lit	电源接通	Power ON
			熄灭	Not lit	电源未接通	Power OFF



4.2 接口定义及接线 (Interface definition and wiring)

端口说明 (Terminal description)	引脚定义 (Pin definition)		接线 (Wiring)	
	序号 (No.)	信号名 (Signal)		说明 (Description)
	1	DO1+	数字信号输出DO1 Digital output DO1	
	6	DO1-	数字信号输出DO1	
	2	DO2+	数字信号输出DO2 Digital output DO2	
	7	DO2-	数字信号输出DO2	
	3	DO3+	数字信号输出DO3 Digital output DO3	
	8	DO3-	数字信号输出DO3	
	9	DI1	数字信号输入DI1 Digital input DI1	
	4	DI2	数字信号输入DI2 Digital input DI2	
	10	DI3	数字信号输入DI3 Digital input DI3	
	5	DI4	数字信号输入DI4 Digital input DI4	
	15	DI5	数字信号输入DI5 Digital input DI5	
	11	COM	24V电源输入 24V power supply input	
	12	24V	24V电源输入	
	13	DI-OP	DI公共端 DI common terminal	
14	/	Reserved	Reserved	

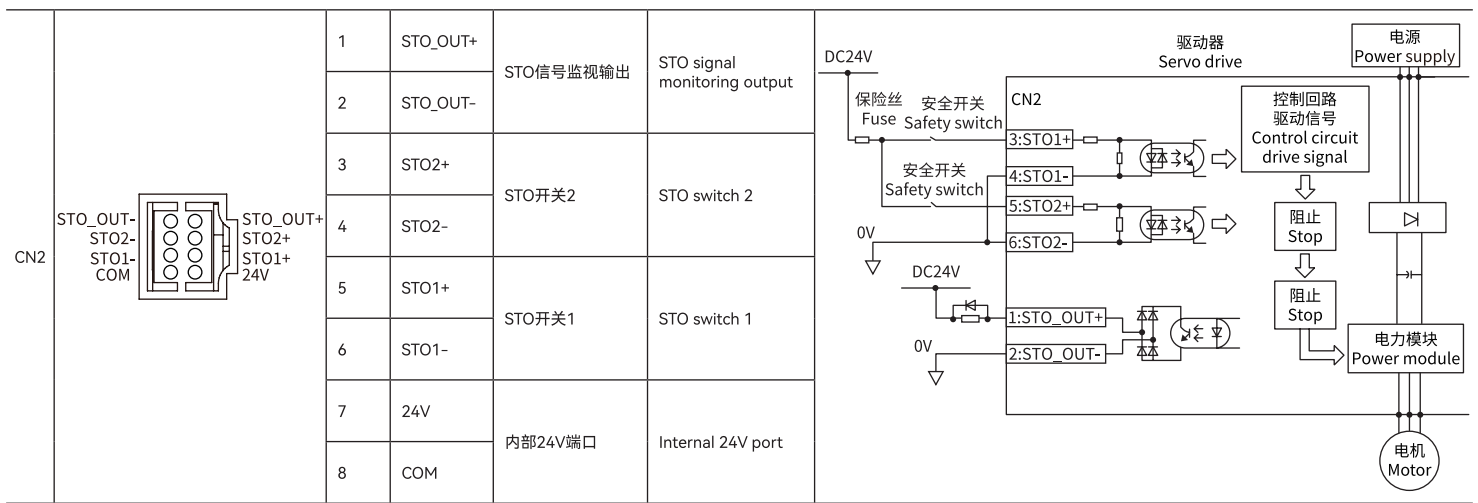

主回路接线 (Main circuit wiring)

单相 AC220V 1kW 及以下 (Single-phase AC220V under 1kW) 单相 AC220V 1.5kW~2.5kW (Single-phase AC220V 1.5kW~2.5kW)

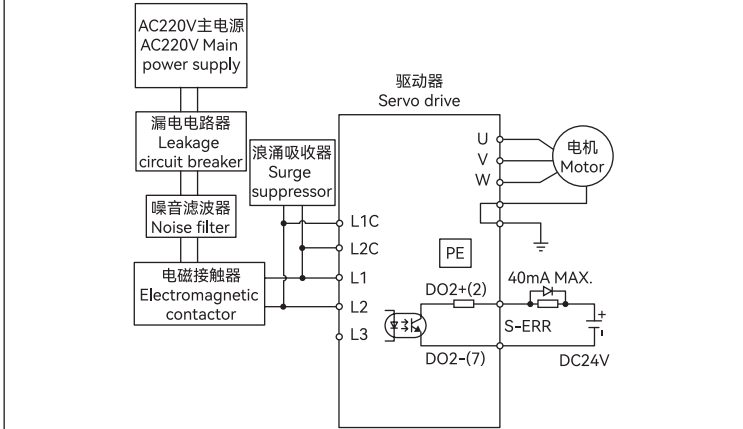
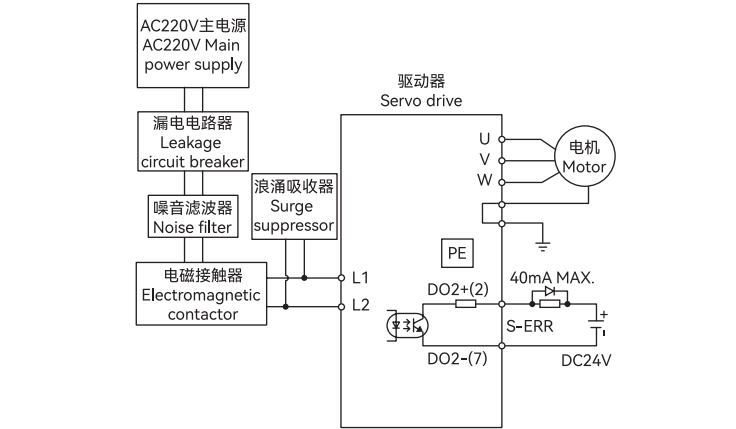

三相 AC220V 1.5kW~2.5kW (Three-phase AC220V 1.5kW~2.5kW)

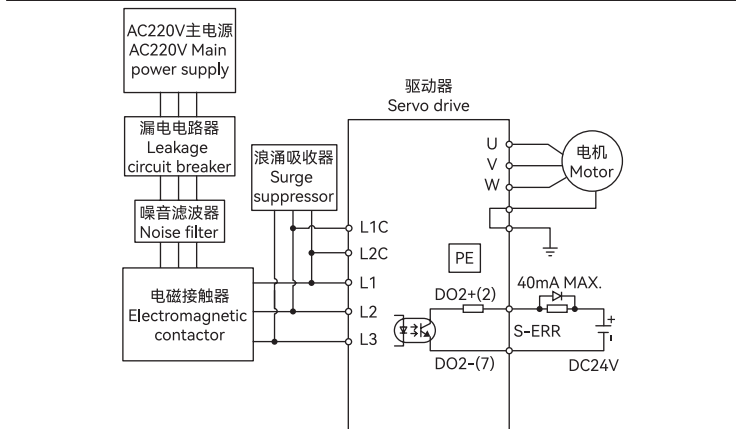

三相 AC380V 2kW~3kW (Three-phase AC380V 2kW~3kW)

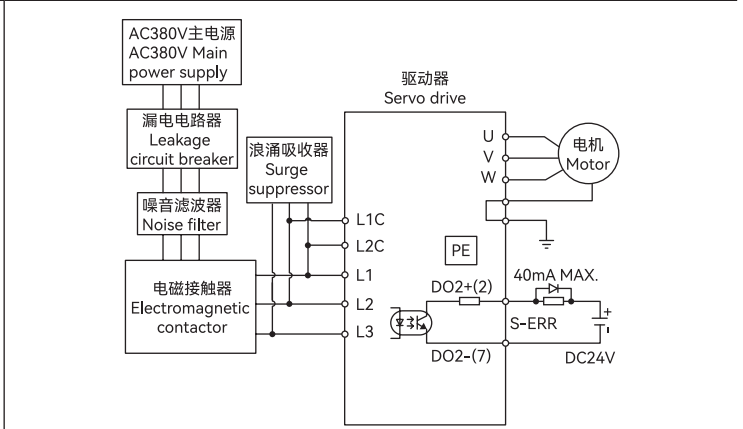

5. 尺寸与重量(Dimension and weight)

100W~400W / 750W~1kW 1.5kW~3kW

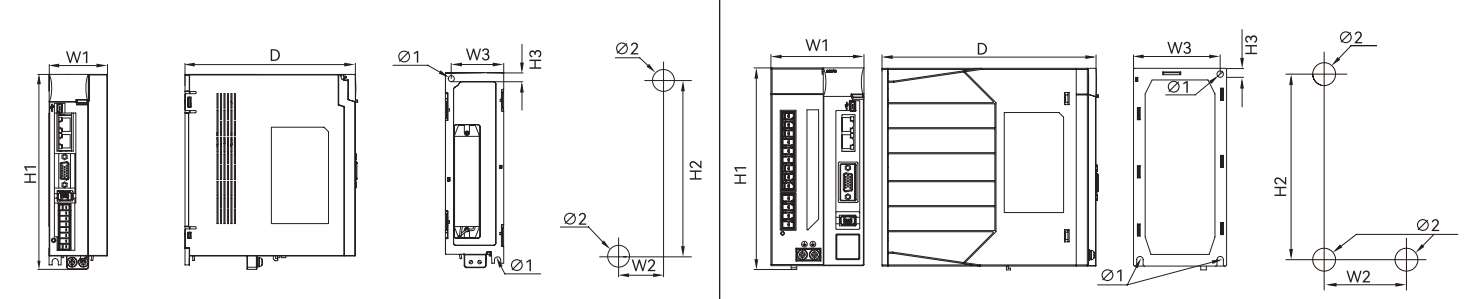

功率 (Power)	外形尺寸 (Dimension): mm							孔径 Ø1 (Hole diameter Ø1): mm	孔径 Ø2 (Hole diameter Ø2): mm	螺丝孔 (Screw hole)	锁紧扭矩 (Tightening torque): N.m	重量 (Weight): kg
	W1	W2	W3	H1	H2	H3	D					
100W~400W	35	25	30	174	162.5	5	152	4.5	5	2*M4	1.2	0.75
750W~1kW	52	41	46.5	174	161.5	5.5	152	5.5	6	2*M4	1.2	1
1.5kW~3kW	80	69	74.5	174	159.5	5	184	5.5	6	3*M5	3.5	1.75

*注: 孔径 Ø1 为驱动器孔径, 孔径 Ø2 为背板打孔孔径。
 *Note: The symbol Ø1 is the hole diameter of the servo drive, and Ø2 is that of the back panel.